

PERFORMANCE MIGHTY MITE QUALITY

Catalog # 34

All Measurements Are In Millimeters Unless Otherwise Stated w/ " .

WE'VE GOT ALL
THE RIGHT PARTS!



UPGRADE TO **MIGHTY MITE** PICK-UPS & PARTS AT YOUR DEALER

3451 West Commercial Avenue • Northbrook, IL 60062 USA • Phone: 847-498-MITE • Fax: 847-498-5370

E-mail: mitesales@mightymite.com • Web: www.mightymite.com

Since the 1970's, Mighty Mite® has supplied quality guitar parts to some of the most renown luthiers in the industry. Our pride and customer service are un-matched and the Mighty Mite® name stands for Quality Performance.

Mighty Mite® Bodies are made from the finest North American woods. Our quality replacement bodies are cut from the finest Pacific coast Maple and American Ash. Our eleven coat bodies are wet sanded between coats wich yeilds a beautiful mirror finish.

We offer, P Bass®, J Bass®, Strat® and Tele® replacement bodies in a wide variety of colors and woods. Flame and Quilted Tops are also available - See color chart for options.

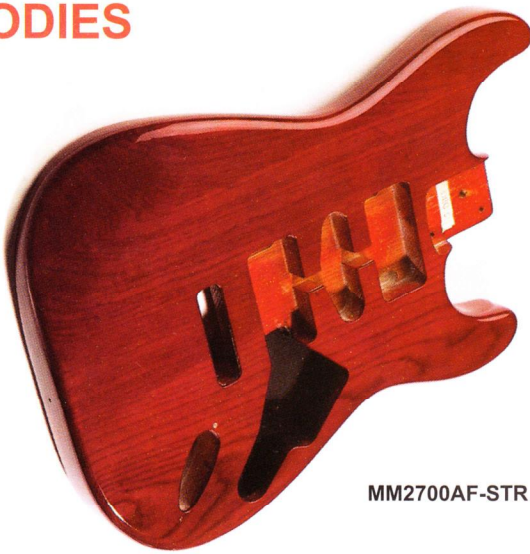

MM2700AF-STR



MM2700AF-STP



MM2702F-2TS



MM2700F-BK



MM2705F-IV



MM2700AF-CRS



MM2703F-RD



MM2700F-CMB



MM2705F-BLB



MM2700AF-STBL



MM2700AF-STBK



MM2700F-CRS

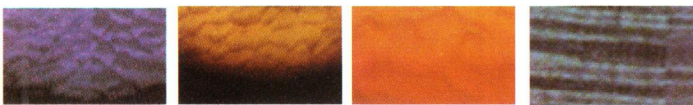

FQ - BLB FQ - 2TS FQ - CRS FF - BLB

Color Chart

- | | |
|---|---|
| 2TS / Ash, Maple, Flame Top, Quilt Top | BK / Ash, Maple |
| BLB / Ash, Maple, Flame Top, Quilt Top | IV / Maple Only |
| CRS / Ash, Maple, Flame Top, Quilt Top | R / Maple Only |
| CMB / Maple Only | F / Finished (Maple) |
| STR / Ash, Maple | AF / Finished (Ash) |
| STP / Ash, Maple | FF / Finished Flame Top Maple |
| STBK / Ash, Maple (Transparent Black) | FQ / Finished Quilt Top Maple |
| STBL / Ash, Maple (Transparent Blue) | MS Maple Sealed AS Ash Sealed |

All Mighty Mite® Bodies Are Available Un-Finished Or Sanded & Sealed

Body Specifications

1. Strat® / Depth = 45mm / Length = 460mm / Width = 322mm
2. P Bass® / Depth = 42mm / length = 506.67mm / Width = 329.47mm
3. J Bass® / Depth = 42mm / Length = 521.08mm / Width = 352.52mm
4. Tele® / Depth = 45mm / Length = 405.17mm / Width = 324.36mm

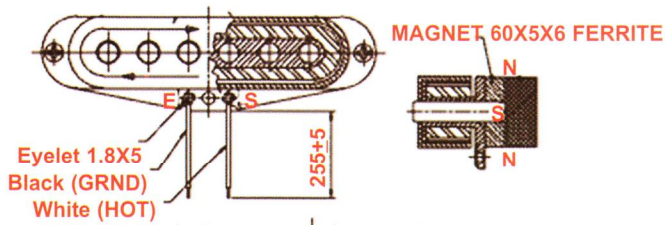

MMPSS-F/BK Single Coil Pickup (Front)
Great Tone / Available In Black or White

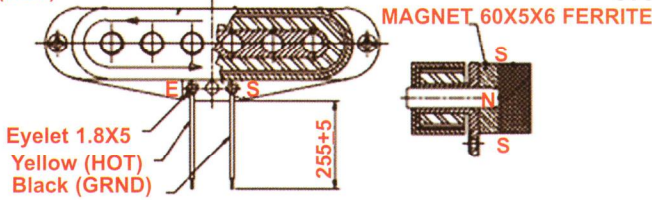

MMPSS-M/BK Single Coil Pickup (Middle)
Great Tone / Available In Black or White

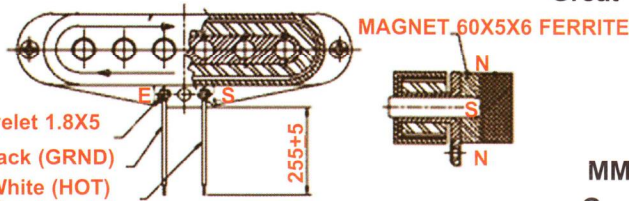

MMPSS-R/BK Single Coil Pickup (Rear)
Great Tone / Available In Black or White



Check Out This Pickup Line

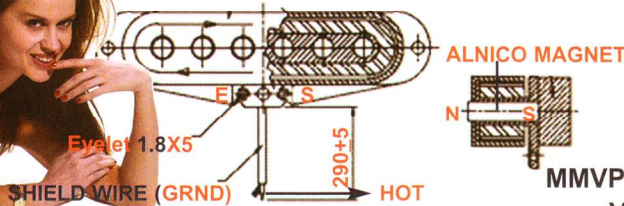

MMVPSS-F/BK ALNICO Single Coil Pickup (Front)
Vintage Tone / Available In Black or White

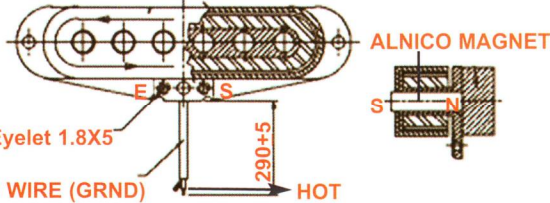

MMVPSS-M/BK ALNICO Single Coil Pickup (Middle)
Vintage Tone / Available In Black or White

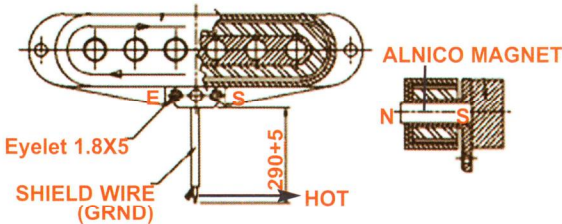

MMVPSS-R/BK ALNICO Single Coil Pickup (Rear)
Vintage Tone / Available In Black or White

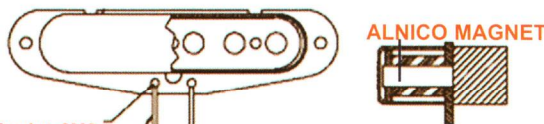

MMTLP-F/C Vintage ALNICO Telecaster® Front Pickup
Classic Vintage Tele® Tone / C (Chrome) G (Gold)

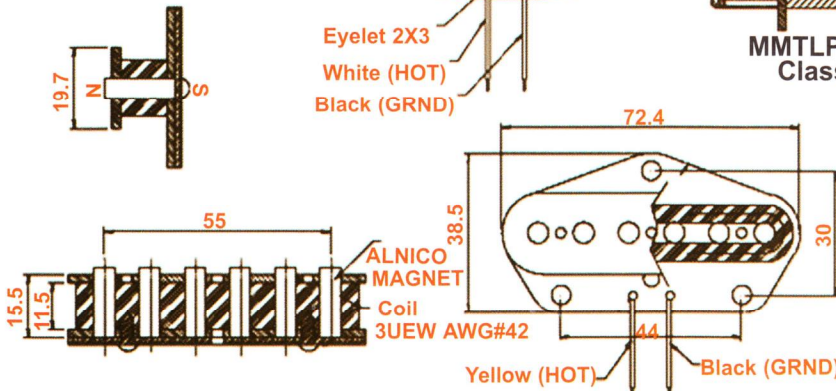

MMTLP-R Standard Telecaster® Rear Pickup
Classic Tele® Tone / Black Only

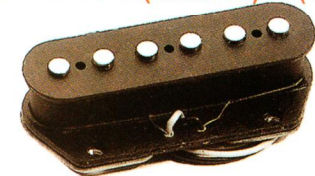

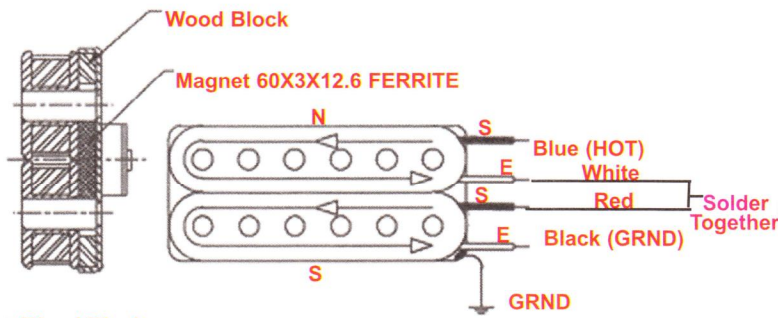

MMHG-F/BK

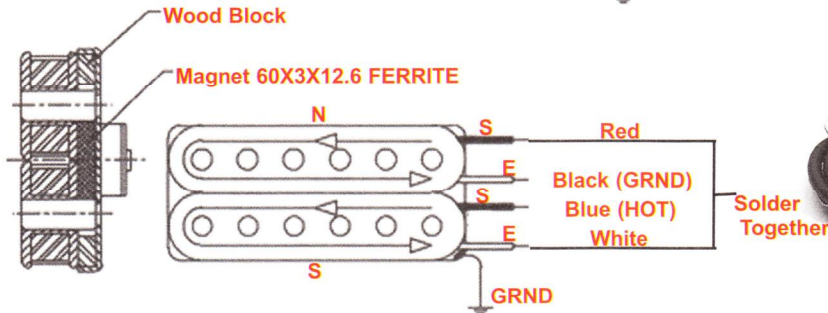

MMHG-R/BK



Mighty Mite® **MIGHTY BUCKERS®** / Super Wound Double Coil Pickups, Add Warmth, Tone and Sustain.

Available In Black or Cream

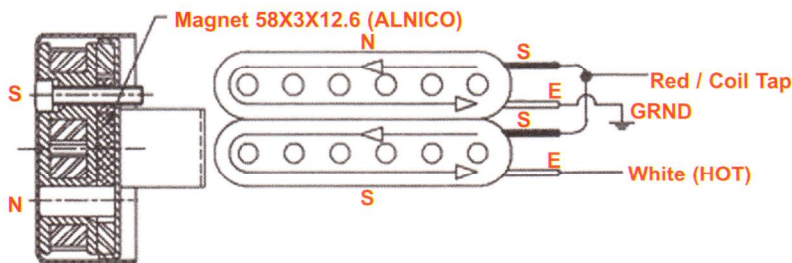

MMHA-F/CR

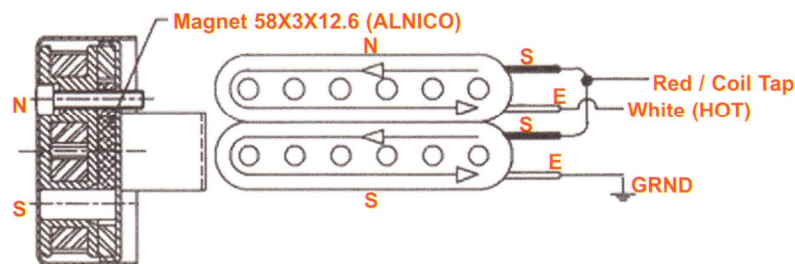
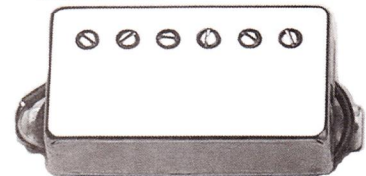

MMHA-R/CR

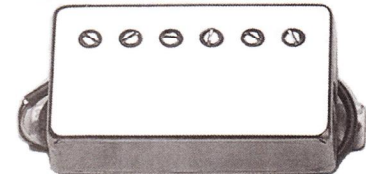

Mighty Mite® **VINTAGE BUCKERS®** / Alnico Magnet Driven, Covered Double Coil Pickups. Classic Vintage Tone.

C (Chrome) G (Gold)

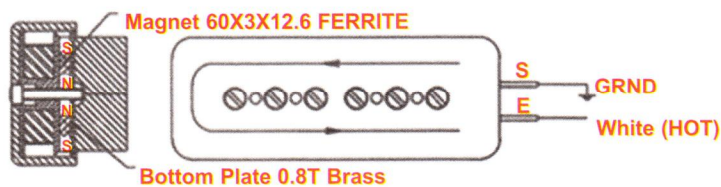

MMP90-F/BK

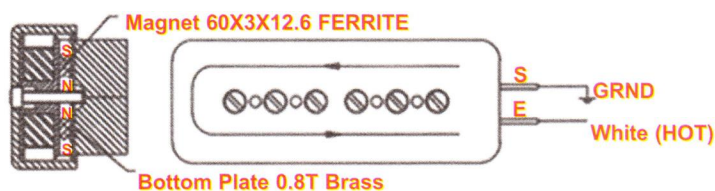
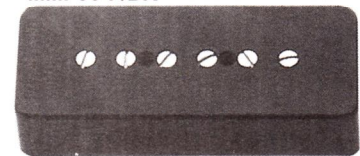

MMP90-R/BK

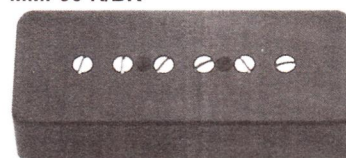

Mighty Mite® **MIGHTY P'S®** / Classic P-90 Design, Awsome Tone And Warmth.

Available In Black or Cream

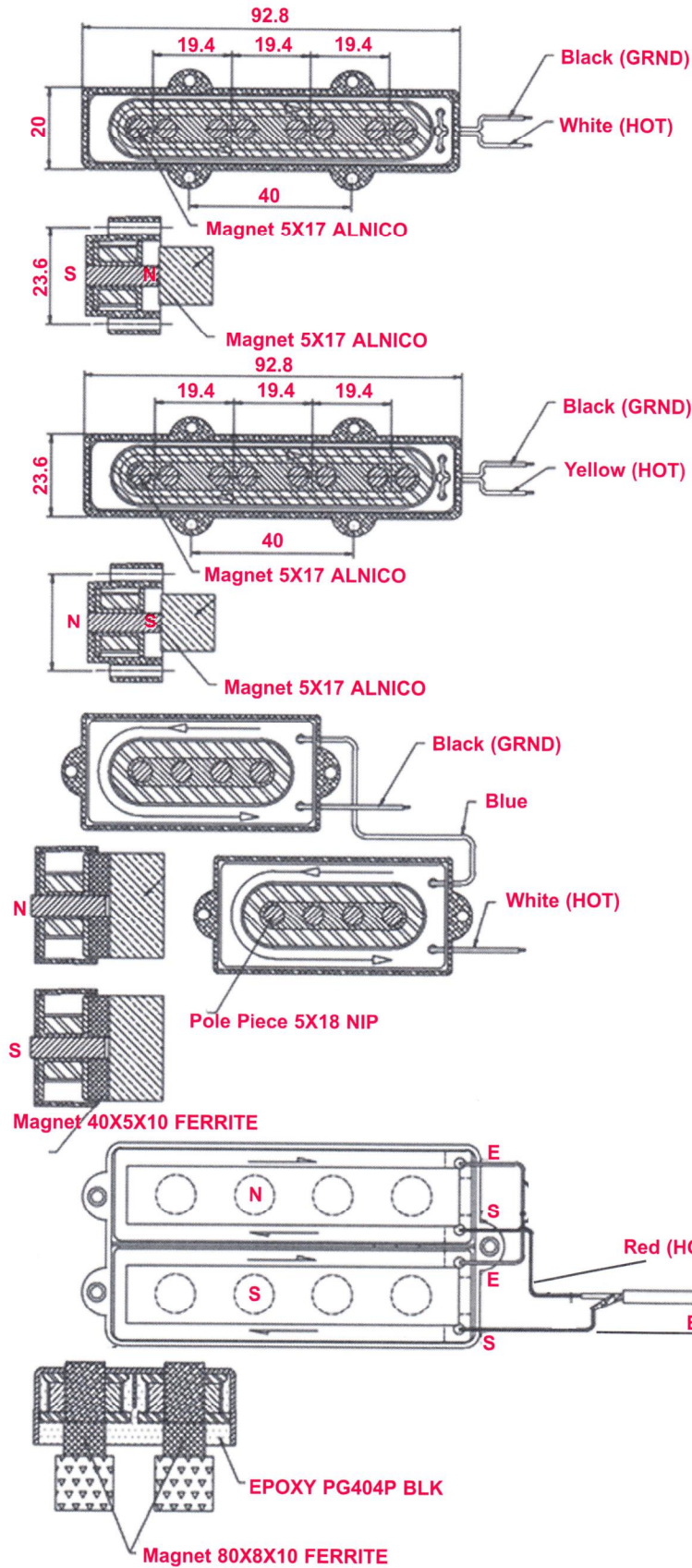

MM1040-1

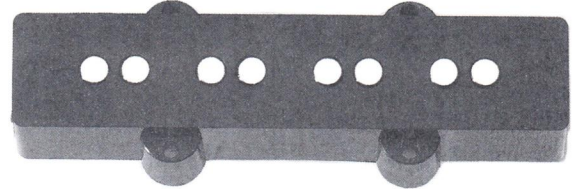

Mighty Mite® J-Bass® Pickups / ALNICO Magnet Driven, Punchy Bass Tone, For Players Looking For A Classic J-Bass® Sound.

MM1041-1

Available In Black

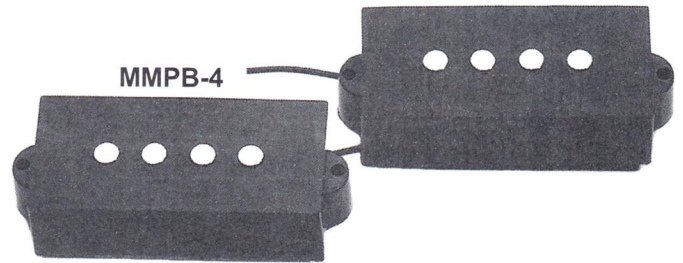
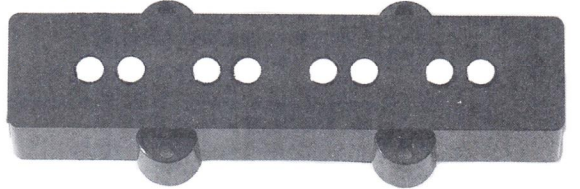

Mighty Mite® P-Bass® Split Pickup / Clear And Bright Tone, Low Noise, Classic P-Bass® Tone.

Available In Black

MMFR-4

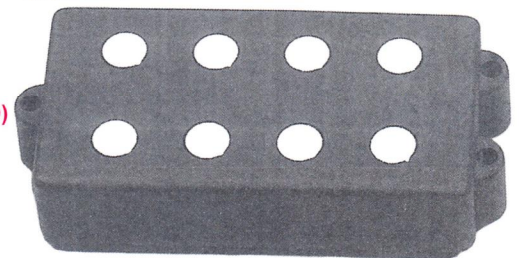

Mighty Mite® Bass Humbucker / High Output Without Hum And Noise, Clear And Punchy Tone.

Available In Black

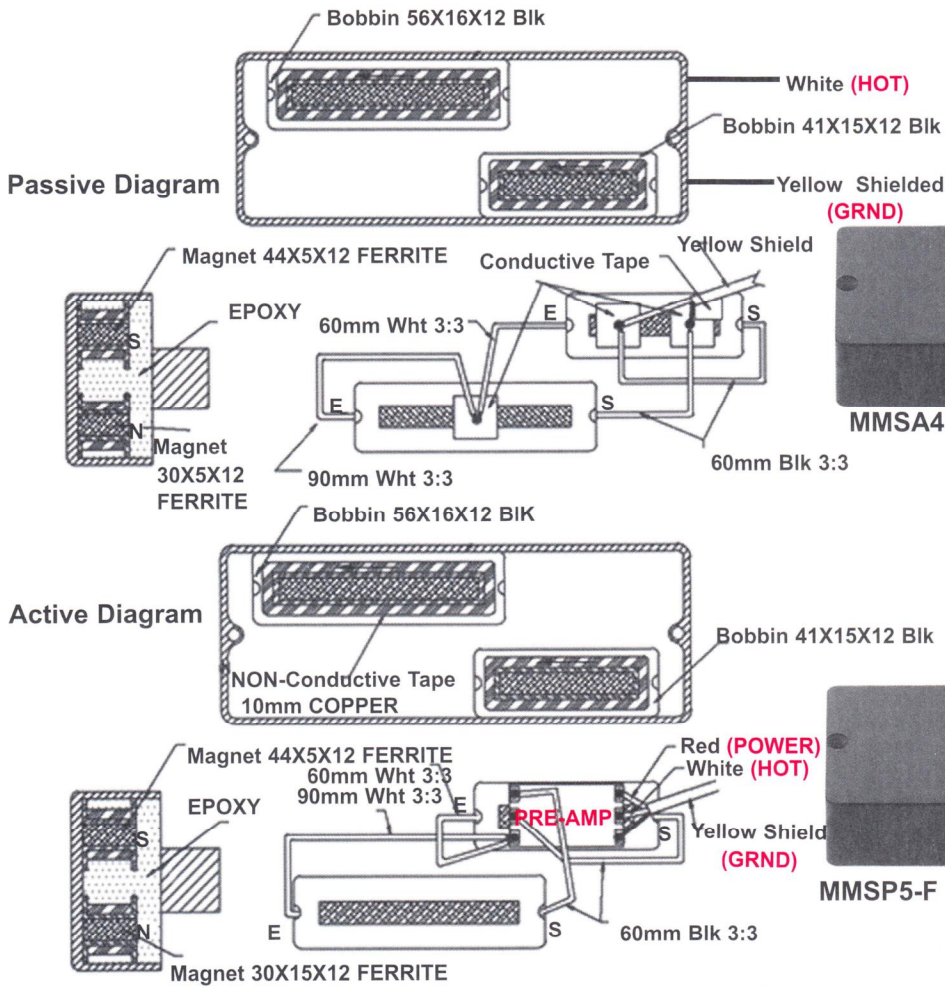

DIAGRAM NOTE: The Passive 4 & 5 String Pickups Use The Same Diagram. The 4-5-6 String Active Pickups Use The Same Diagram

Mighty Mite® Introduces Our New Line Of Active and Passive Soap Bar Bass Pickups. Pounding Low's, Powerful Mids, Incredible Tone and Clarity.

Recommended Use w/ The MM114 Active Bass Control Circuit

MMSP4-F



Mighty Mite® 4 String Passive Soapbar Pickups.

MMSP4-R



MMSA4-F

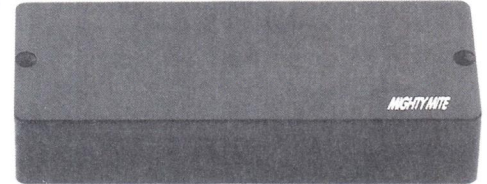

Mighty Mite® 4 String Active Soapbar Pickups.

MMSA4-R

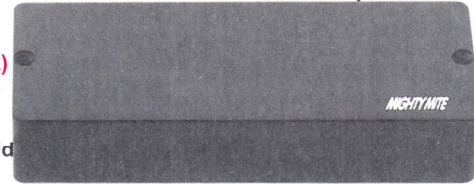

MMSP5-F



Mighty Mite® 5 String Passive Soapbar Pickups.

MMSP5-R



MMSA5-F



Mighty Mite® 5 String Active Soapbar Pickups.

MMSA5-R



MMSA6-F



MMSA6-R



Mighty Mite® 6 String Active Soapbar Pickups.

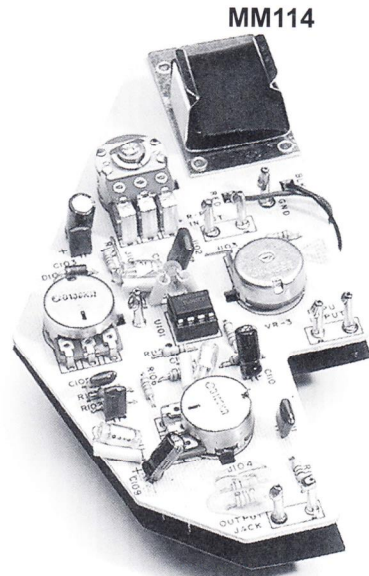
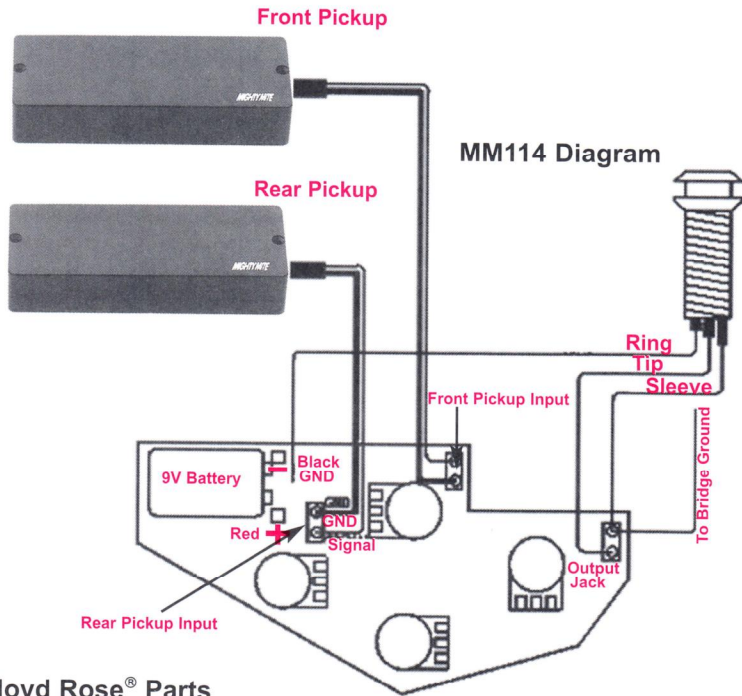

Mighty Mite® Active Bass Control Pre-Amp, w/ Master Volume, Fade, Treble & Bass.

Floyd Rose® Parts

Part No.	Description	Ref No.
MM3000C	Base Plate (Chrome)	1
MM3000G	Base Plate (Gold)	1
MM3000B	Base Plate (Black)	1
MM3100	Fine Tuner Adjustment Spring	2
MM3200	Spring Holder Plate	3
MM3300	Tremolo Block / & Locking Screw	4/5
MM3500	Saddle Lock Down Screw (Pkg 6)	6
MM3600	String Holder Block (Pkg 6)	7
MM3700C	Bridge Saddle 1 & 6 (Chrome)	8
MM3700G	Bridge Saddle 1 & 6 (Gold)	8
MM3700B	Bridge Saddle 1 & 6 (Black)	8
MM3701C	Bridge Saddle 2 & 5 (Chrome)	8
MM3701G	Bridge Saddle 2 & 5 (Gold)	8
MM3701B	Bridge Saddle 2 & 5 (Black)	8
MM3702C	Bridge Saddle 3 & 4 (Chrome)	8
MM3702G	Bridge Saddle 3 & 4 (Gold)	8
MM3702B	Bridge Saddle 3 & 4 (Black)	8
MM3800	Fine Tuner Screw (Pkg 6)	9
MM3900	String Holder Locking Bolt (Pkg 2)	10
MM4000	Stud & Stud Insert	11
MM4100	Tremolo Arm Bushing G/B/C	14
MM4100	Key Washer	15
MM4100	Bottom Washer	16
MM4100	Tremolo Arm Lock Nut G/B/C	17
MM4200	Spring Claw Hook	18
MM4300	Tremolo Springs (Pkg 6)	19
MM4400	Tremolo Claw Hook Screw (Pkg 10)	20

Floyd Rose® Parts Diagram

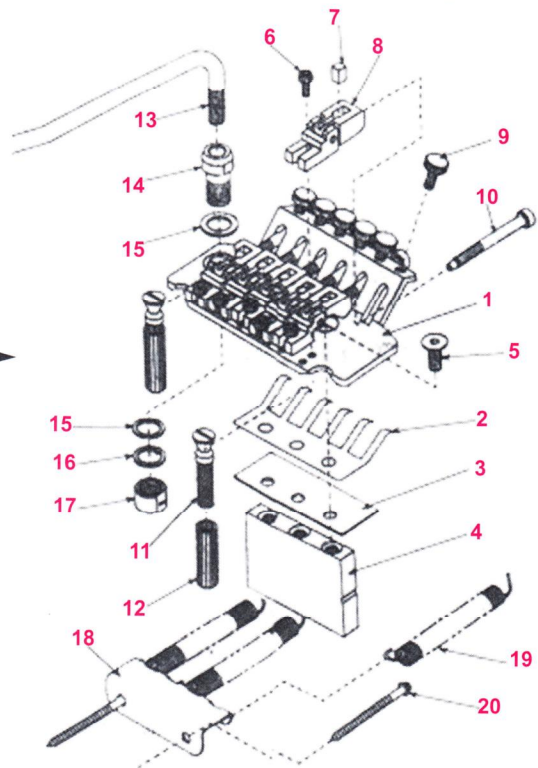

MM100

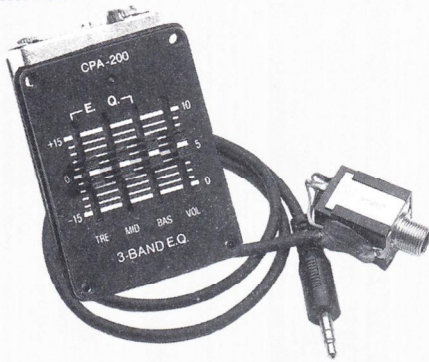

Mighty Mite® 3 Band EQ / Pre-Amp.

MM116



Mighty Mite® 4 Band Active EQ w/ Treble, Bass, Mid, 1Khz - 2Khz Control And Battery Light.

MM104

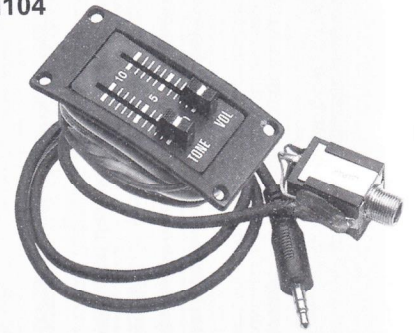

Mighty Mite® Transducer Pickup, w/ Tone Controls.

MM102

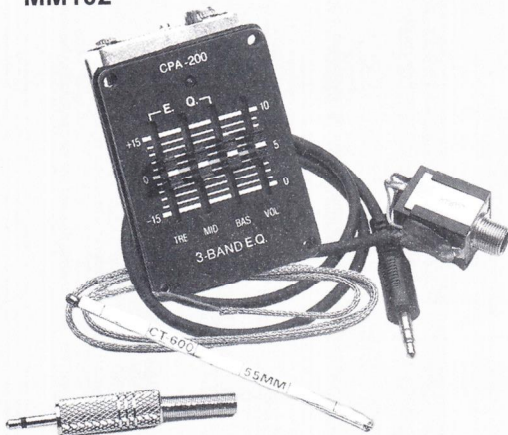

Mighty Mite® 3 Band EQ / Pre-Amp w/ Slim Jim® Bridge Mount Pickup.

MM103



Mighty Mite® 4 Band Active EQ w/ Treble, Bass, Mid, 1Khz - 2Khz Control And Battery Light w/ Slim Jim® Under The Saddle Acoustic Guitar Pickup.

MM110

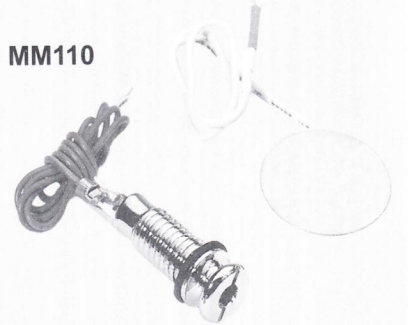

Mighty Mite® Transducer Pickup, Internal Mounting w/ End Pin Jack.

MM505



Mighty Mite® 3 Band Active EQ, Plus Volume Control.

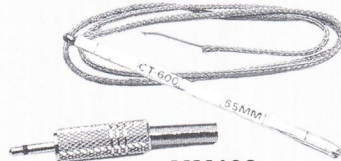

MM108

Slim Jim® Under The Saddle Acoustic Bass Guitar Pickup.

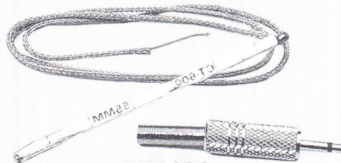

MM106

Slim Jim® Under The Saddle Acoustic Guitar Pickup.

MM555

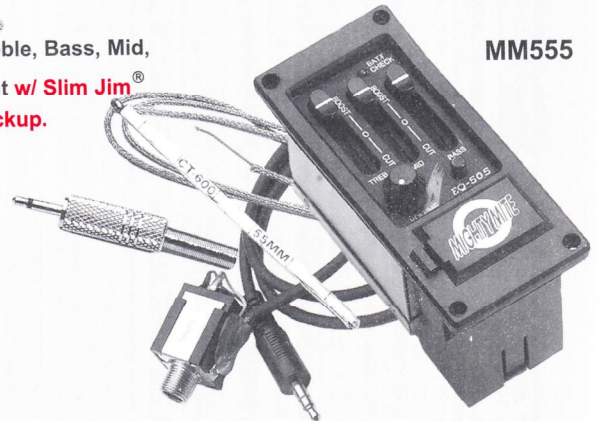

Mighty Mite® 3 Band Active EQ, Plus Volume Control, w/ Slim Jim® Bridge Mount Pickup.

MM7580



Mighty Mite® 4 Band Active EQ, Plus Volume Control.

MM7585

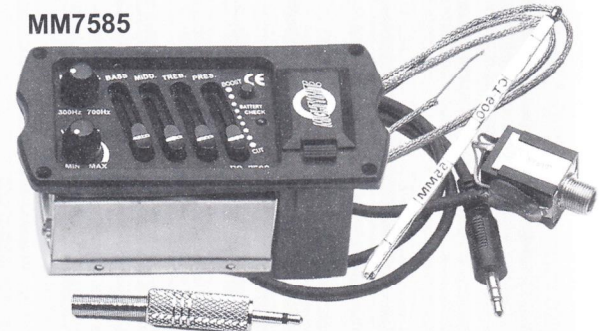

Mighty Mite® 3 Band Active EQ, Plus Volume Control, w/ Slim Jim® Bridge Mount Pickup.

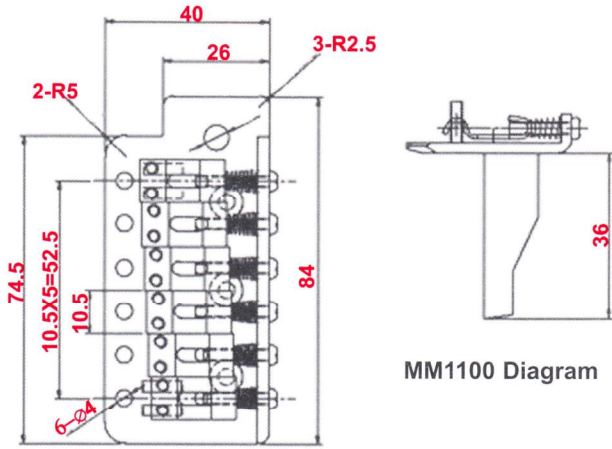

MM1100 Diagram

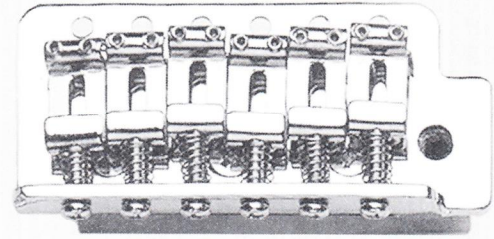

MM1100

Mighty Mite® Vintage Strat® Style Six Screw Mounted Tremolo Unit With Adjustable Saddles With Arm And Hardware. Left Handed Version Available.

(MM1100L) MM1100C (Chrome) MM1100G (Gold)

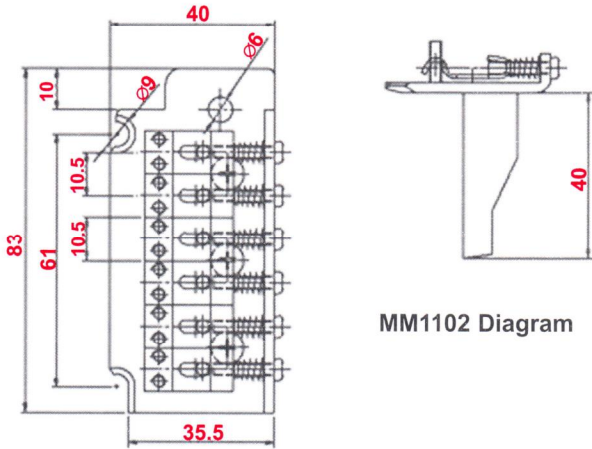

MM1102 Diagram

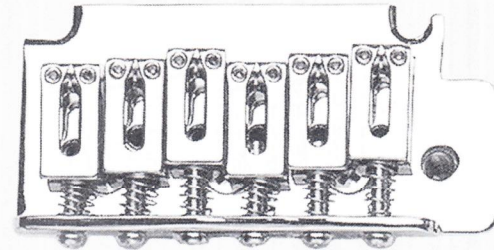

MM1102

Mighty Mite® Strat® Style Floating Tremolo System With Adjustable Saddles With Arm And Hardware.

MM1102C (Chrome) MM1102G (Gold)

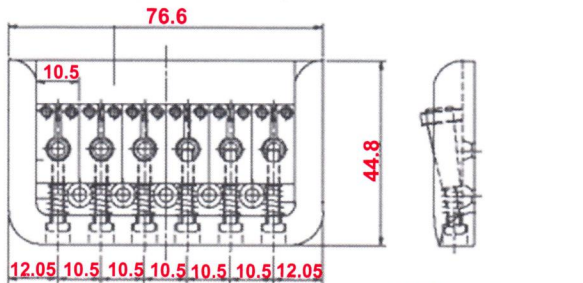

MM2106 Diagram

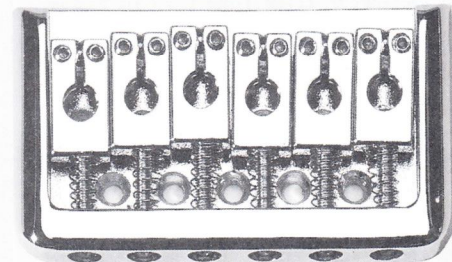

MM2106C

Mighty Mite® Hard Tail Bridge, Quality Heavy Duty Construction, Adjustable Saddles With Hardware.

C (Chrome) B (Black) G (Gold)

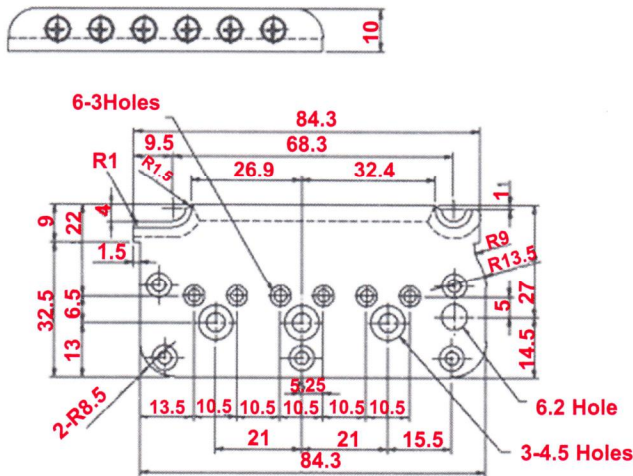

MM1112 Diagram

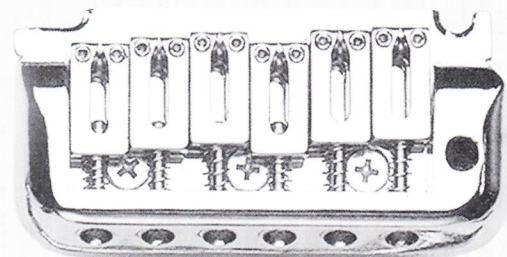

MM1112

Mighty Mite® Full Action II Tremolo System Complete With Arm and Hardware.

MM1112 (CHROME) MM1114 (BLACK) MM1116 (GOLD)

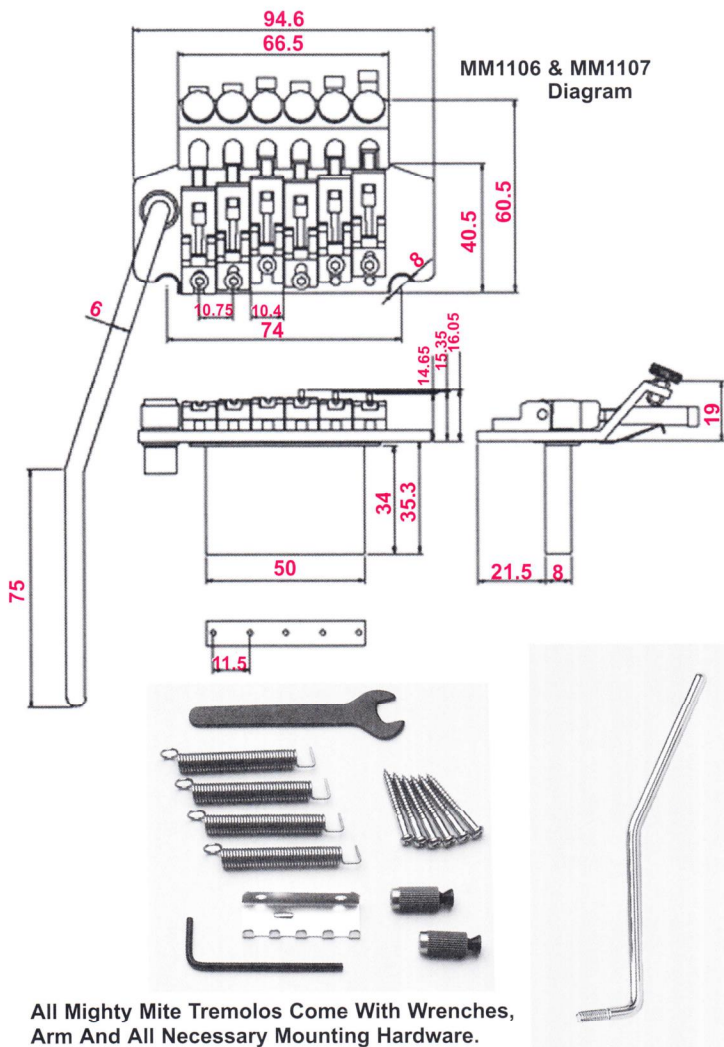

All Mighty Mite Tremolos Come With Wrenches, Arm And All Necessary Mounting Hardware.

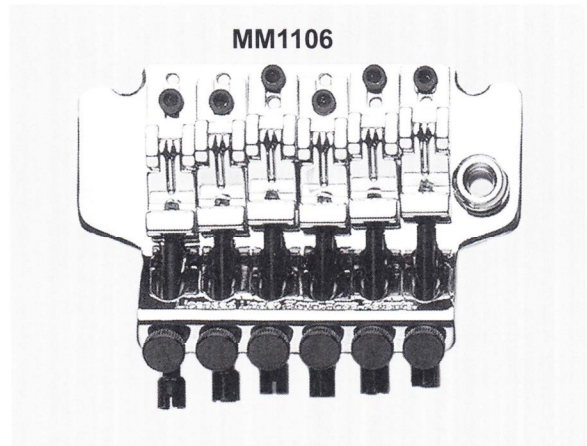

Mighty Mite® Licensed Floyd Rose® Non-Locking Tremolo System. For The Player Who Wants To String And Go Without The Hassle Of Cutting Strings.
MM1106 (CHROME) MM1106B (BLACK)

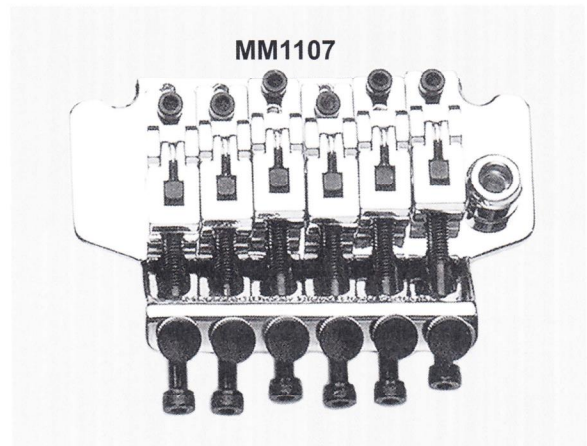

Mighty Mite® Licensed Floyd Rose® Locking tremolo System. This Legendary System Offers Un-Matched Stability, Sustain, and Tuning.
MM1107 (CHRM) MM1108 (BLK) MM1111 (GLD)

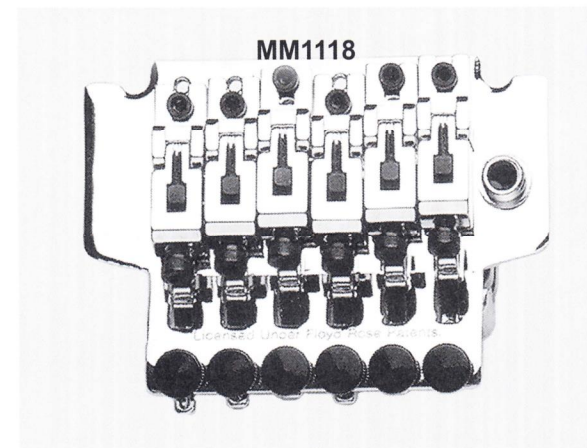
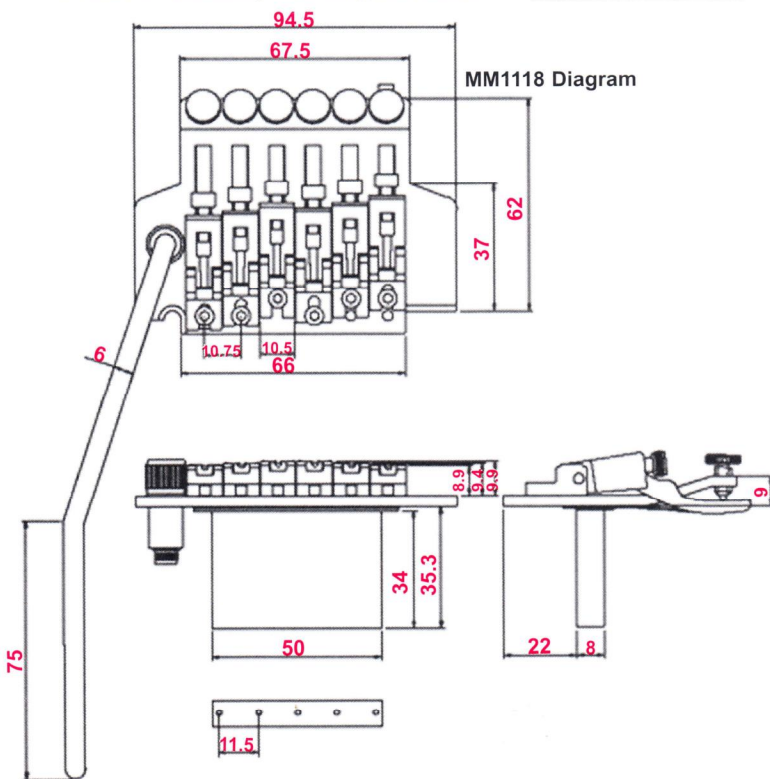

Mighty Mite® Licensed Floyd Rose® Low-Pro Locking Tremolo System. After Years Of Innovation This Is The Best Design Yet.
MM1118 (CHRM) MM1120 (BLK) MM1122 (GLD)

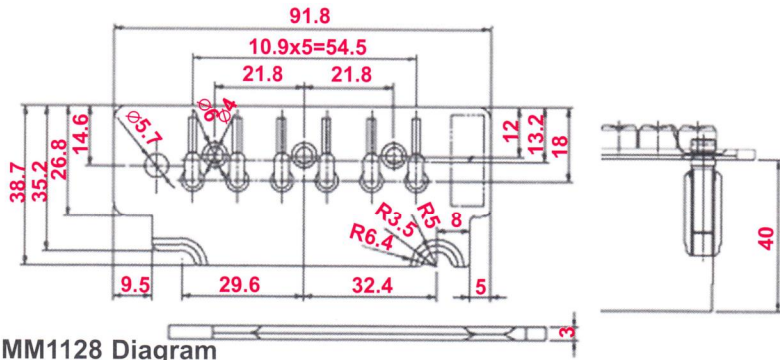

MM1128 Diagram

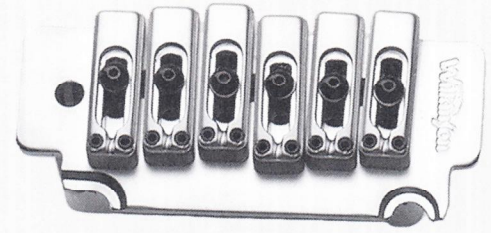
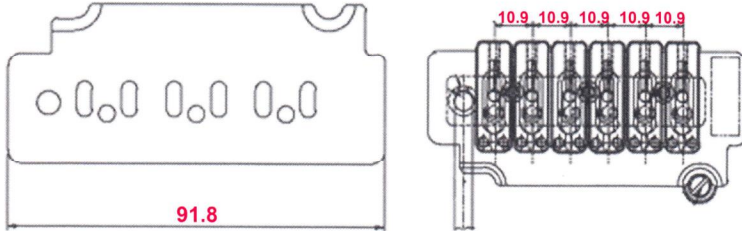

MM1128

Mighty Mite® Licensed Wilkinson® VS100 Tremolo System. High Quality Tremolo Featuring Height Adjustable Stainless Steel Saddles And Hardened Steel Base Plate. Enhanced Sustain And Tone With Better Tuning And Intonation.

MM1128 (CHRM) MM1130 (GLD)

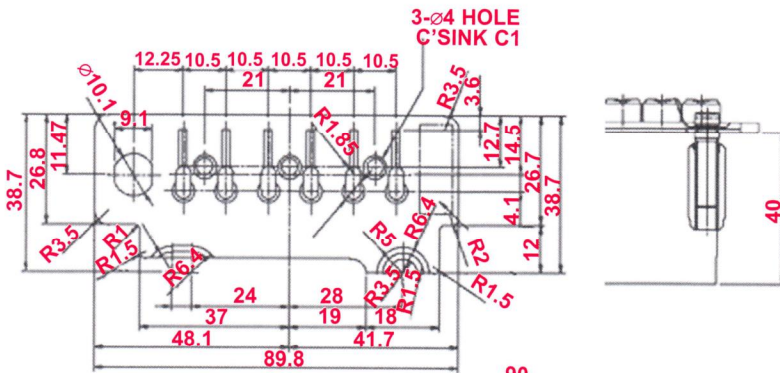

MM1171 Diagram

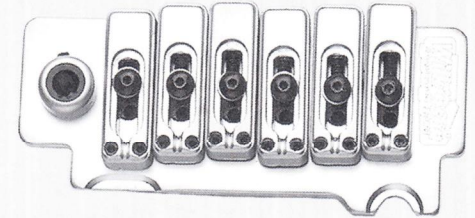
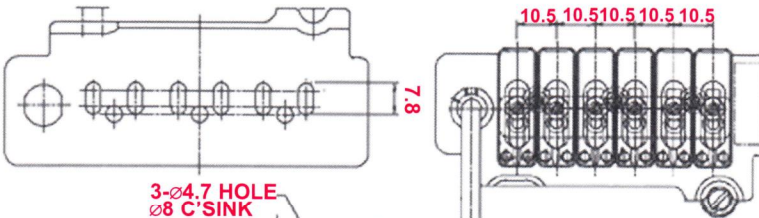

MM1171

Mighty Mite® Licensed Wilkinson® VS50 Tremolo System. Hot Rod Your American Strat® With The VS50 With NO Modifications To Your Guitar. High Quality Tremolo Featuring Height Adjustable Stainless Steel Saddles And Hardened Steel Base Plate. Enhanced Sustain And Tone With Better Tuning And Intonation.

C (Chrome) B (Black) G (Gold)

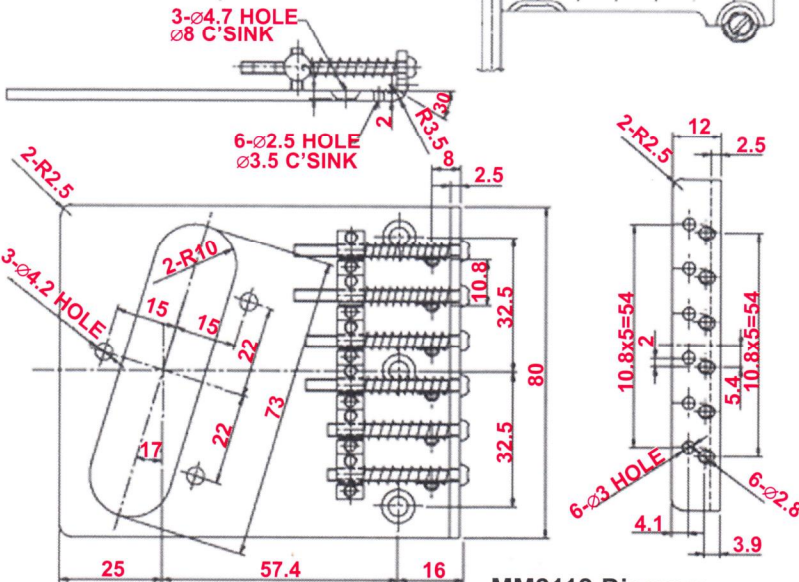

MM2112 Diagram

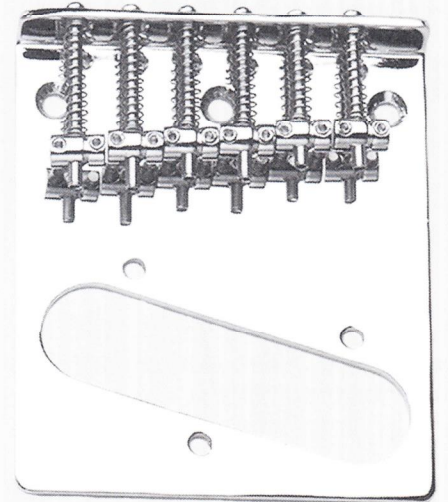

MM2112

Mighty Mite® Traditional Tele® Bridge. Adjustable Saddles And Designed For Through The Body Or Through The Back Of The Bridge Mounting.

MM2112C (Chrome) MM2112G (Gold)

Wilkinson® is a trademark of the Wilkinson® Corp, Mighty Mite® is not affiliated with Wilkinson®

Strat®, P-Bass®, J - Bass®, and Tele® are trademarks of Fender Musical Instruments Corp. Mighty Mite® is not affiliated with Fender Musical Instruments Corp.

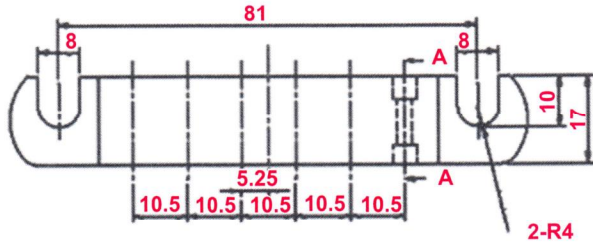

MM2103 Diagram

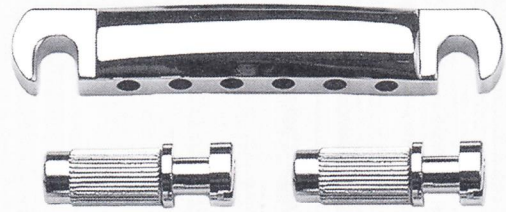

MM2103

Mighty Mite® Stop Tailpiece for Gibson® Style Solid Body Guitars, With Height Adjustable Threaded Mounting Post And Knurled Bushings.

MM2103 (Chrome) MM2105 (Gold)

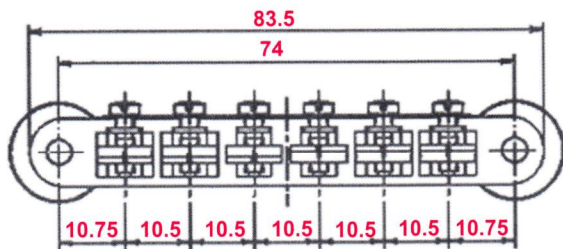

MM2104 Diagram

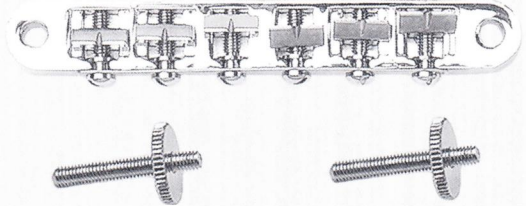

MM2104

Mighty Mite® Tune-O-Matic® Style Bridge For Solid Body Guitars With Standard Mounting Posts And Bushings.

MM2104 (Chrome) MM2102 (Gold)

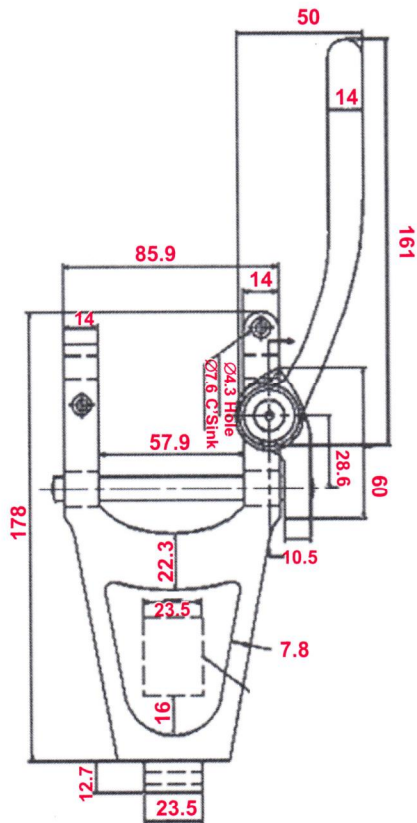

MM1124 Diagram

MM1124

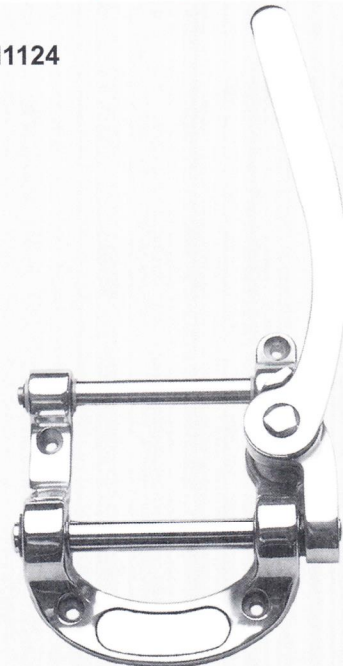

Mighty Mite® Bigsby® Style Vibrato Tailpiece Featuring A String Mounting Bar Floating On Low-Friction Bearings, Cast Aluminum Frame, Stainless Steel Arm, Nickel Plated String Bar.

MM1124 (CHROME) MM1128 (GOLD)

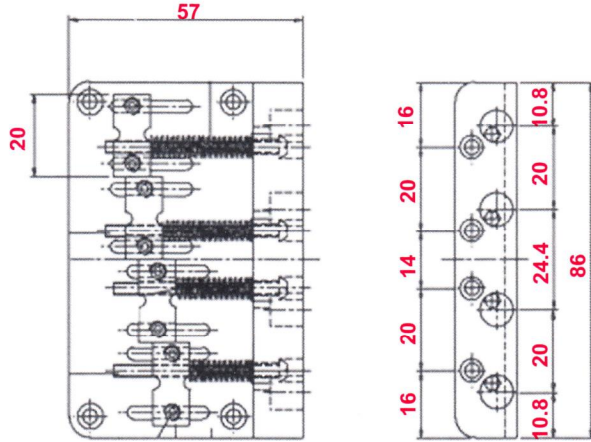

MM1110 Diagram

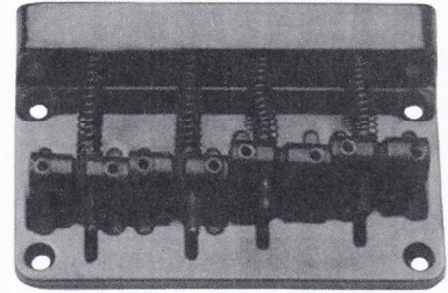
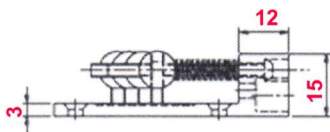

MM1110

Mighty Mite® 4 String P-Bass® Style bass Bridge With Adjustable Saddle Height And Intonation.
Available In Black Or Chrome

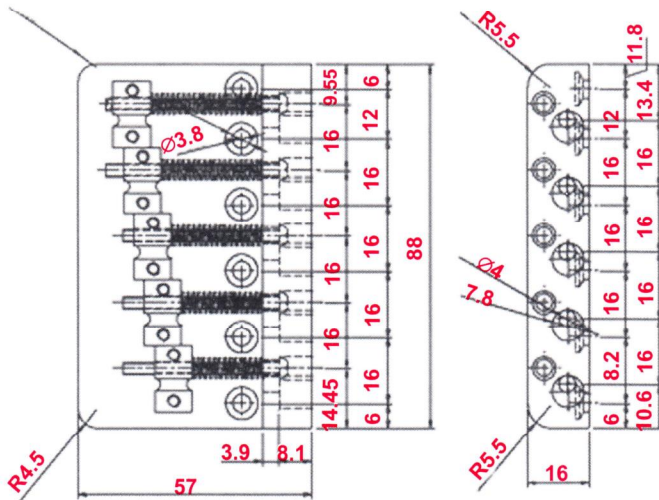

MM1115 Diagram

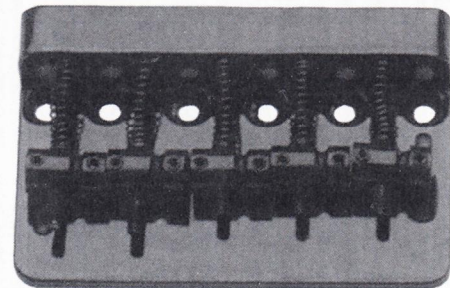
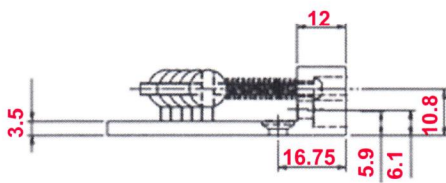

MM1115

Mighty Mite® 5 String Bass Bridge With Adjustable Saddle Height And Intonation.
Available In Black Or Chrome

MM1204 Diagram

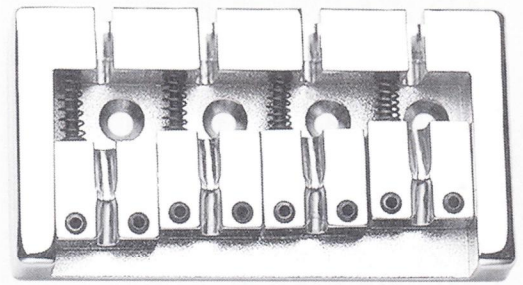
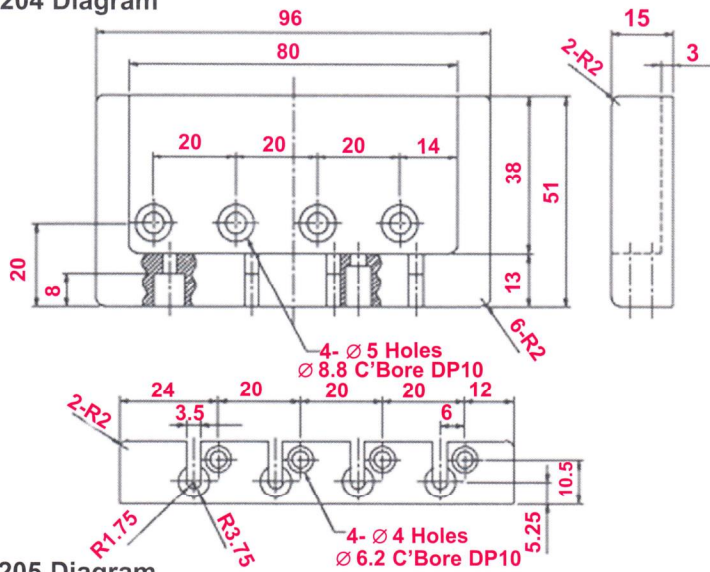

MM1204

Mighty Mite[®] 4 string Bass Bridge
Solid Brass Construction Provides Superior Tone, Warmth And Sustain. Adjustable Saddle Height And Intonation With 4 Screw Mounting.
C (Chrome) B (Black) G (Gold)

MM1205 Diagram

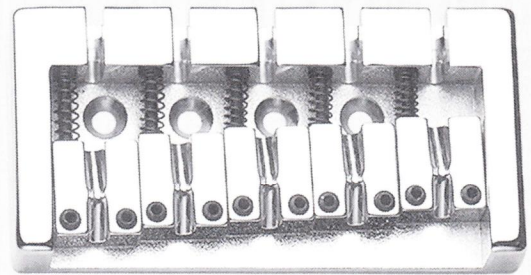
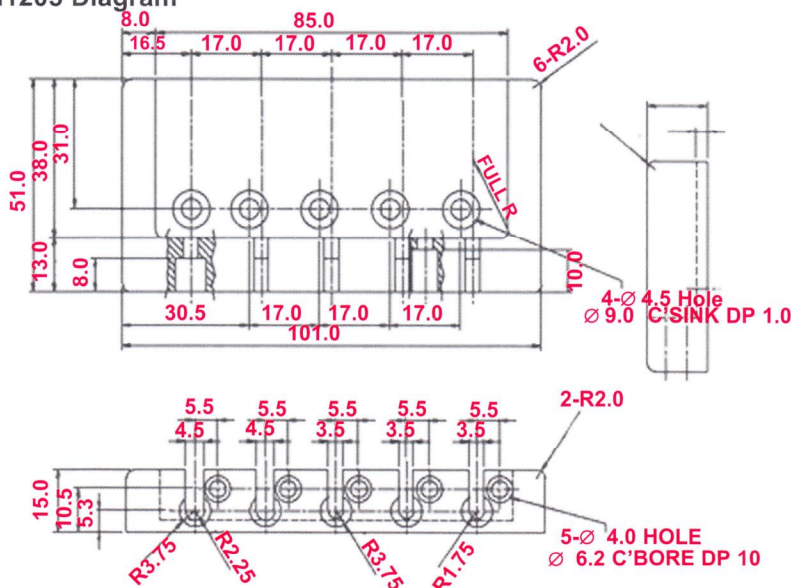

MM1205

Mighty Mite[®] 5 String Bass Bridge
Solid Brass Construction Provides Superior Tone, Warmth And Sustain. Adjustable Saddle Height And Intonation With 4 Screw Mounting.
C (Chrome) B (Black) G (Gold)

MM1206 Diagram

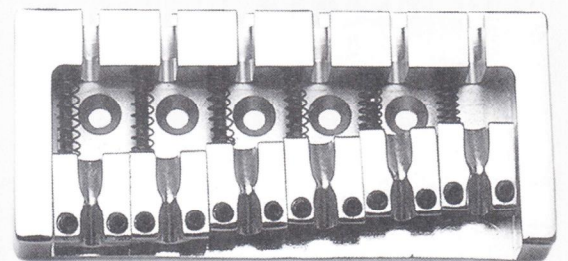
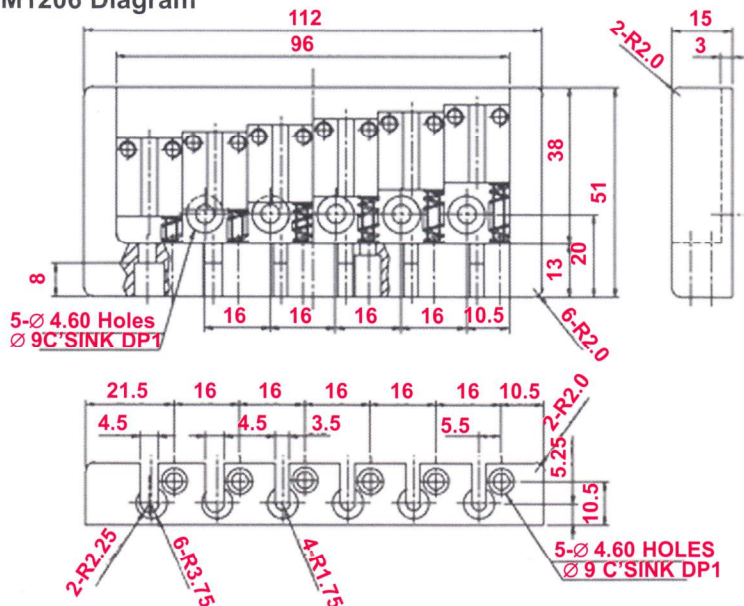

MM1206

Mighty Mite[®] 6 String Bass Bridge
Solid Brass Construction Provides Superior Tone, Warmth And Sustain. Adjustable Saddle Height And Intonation With 5 Screw Mounting.
B (Black) G (Gold)

Mighty Mite®
 Butterfly Pearloid Button,
 Lyra Style, Nylon Rollers
 With Nickel Plate.
MM6005G (Gold Plate)

MM6005C

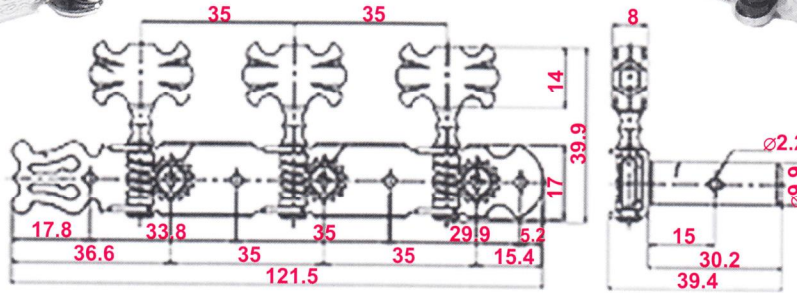
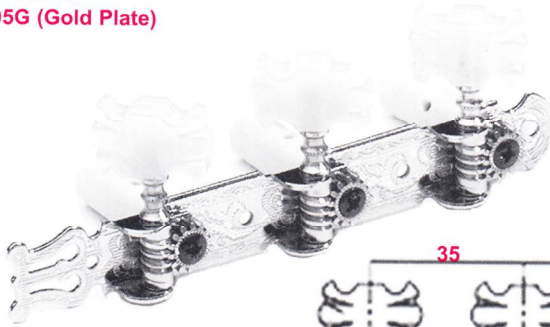

MM6006C

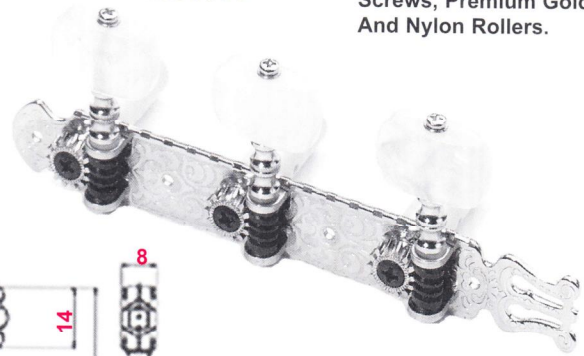

Mighty Mite® Handmade Pearloid
 Button, Adjustable Tension, With
 Engraved Lyra Plate, Black Worn
 Screws, Premium Gold Plating
 And Nylon Rollers.

MM6007C



Mighty Mite® Mini Button 12 String 6x6 Set Of
 2 Pieces Chrome Plating.

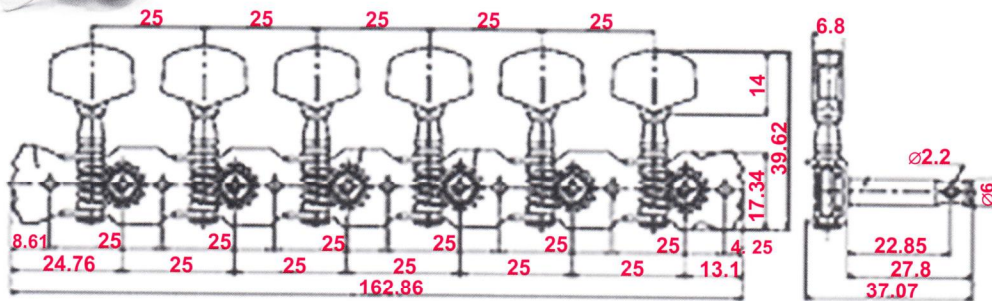

MM6004

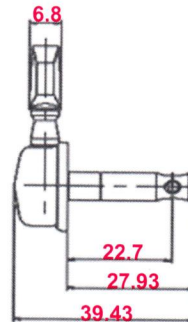
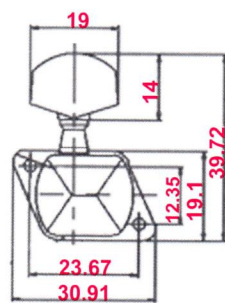
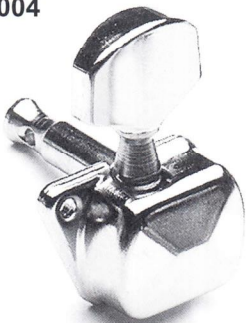

MM6004L

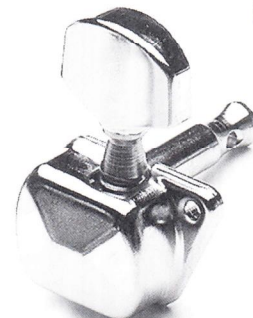

Mighty Mite® 3x3 Economy Machine Heads, Available In Right Handed And Left Handed Set Of 6.
 (Chrome Only)

MM6000C

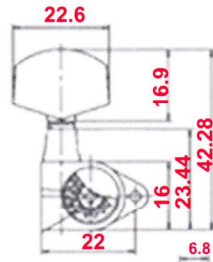

Mighty Mite® 3X3 Machine Head With Single Screw Flange Set Of 6.
C (Chrome) B (Black) G (Gold)

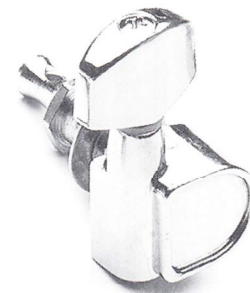
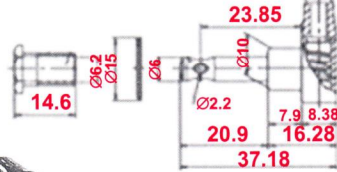

MM6001C

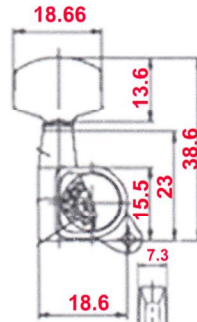

Mighty Mite® 6 In-Line Mini Button Machine Head With Offset Screw Set Of 6.

C (Chrome) B (Black) G (Gold)

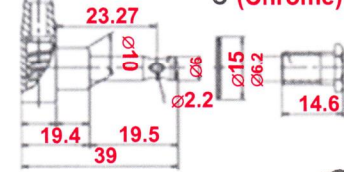

MM6002C

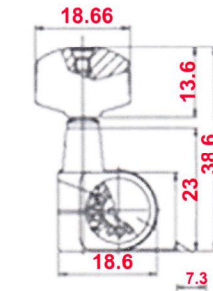

Mighty Mite® 6 In-Line Mini Button Machine Head With Screwless Mounting Set Of 6.

C (Chrome) B (Black) G (Gold)

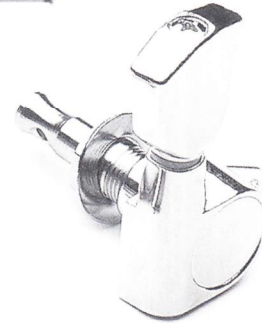
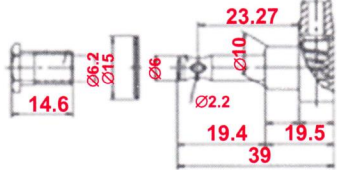

MM6003C

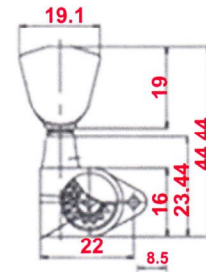

Mighty Mite® Venetian Style Button, 3x3 With Offset Screw Set Of 6.

C (Chrome) G (Gold)

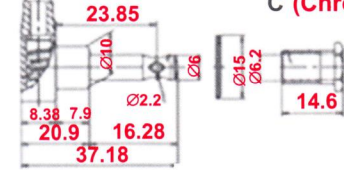

MM6009C

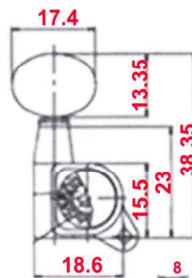

Mighty Mite® Traditional Style Machine Head 6 In Line Set Of 6.

C (Chrome) B (Black) G (Gold)

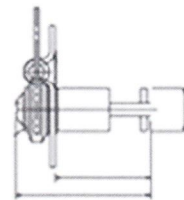
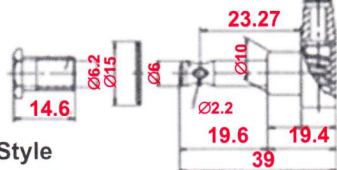

MM6008C

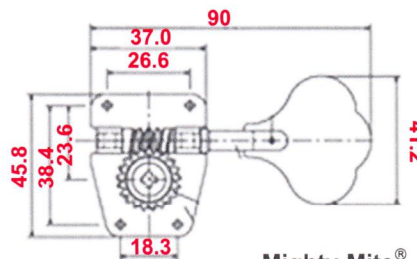

Mighty Mite® Electric Bass Open Gear Style Slotted Post With Bushing, 20:1 Gear Ratio, Set Of 4. C (Chrome) B (Black)





MM909C

Mighty Mite® Metal Dome Control Knob
With Set Screw.
C (Chrome) B (Black) G (Gold)



MM908

Mighty Mite® Metal Round Control Knob
Without Set Screw.
908 (Chrome) 906 (Black) 907 (Gold)



MM922

Mighty Mite® Telecaster® Control Knob
922 (Chrome) 921 (Black) 923 (Gold)

MM913CR

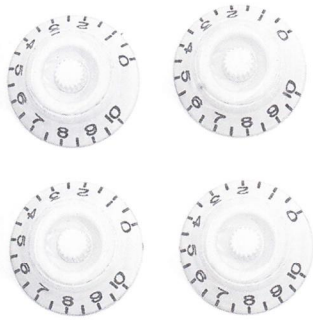

MM913AM



MM913BK



Mighty Mite® Bell Style Control Knobs.

CR (Cream) BK (Black) AM (Amber)

MM914/918



MM916/920



MM910/912



Mighty Mite® Strat® Style Control Knobs.
914/918 (Black) 917/919 (Cream) 916/920 (White)

Mighty Mite® Retro Style Control Knob,
White With Gold Cap.

MM902



Mighty Mite® Gibson® Style Speed Knobs.
902 (Black) 900 (White) 904 (Gold)

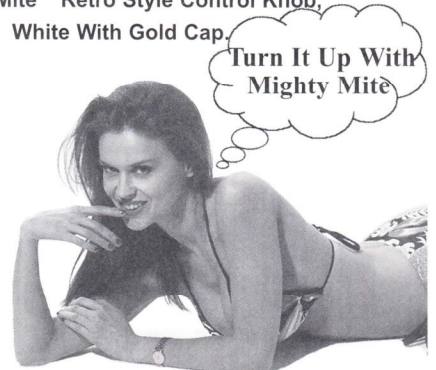

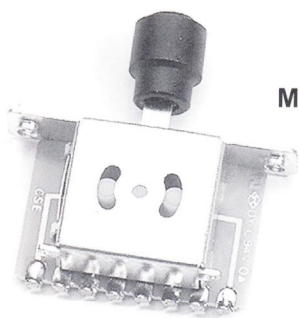

MM533

Mighty Mite® Tele® Replacement
3 Way Switch With Black Knob



MM500

Mighty Mite® 3 Position
Toggle Switch (SPDT)
500 (Black) 501 (White)

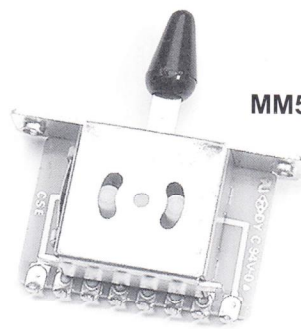

MM511

Mighty Mite® 3 Way Switch
(Double Pole)
511 (Black) 512 (White)

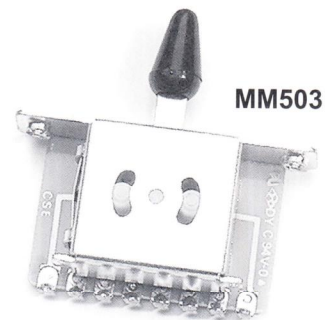

MM503

Mighty Mite® Strat® Replacement
5 Way Switch With Black Knob
(Double Pole)



MM518

Mighty Mite® Mini Toggle
3 Single Terminal System
(SPDT)



MM520

Mighty Mite® Mini Toggle
3 Dual Terminal System
(DPDT)



MM113

Mighty Mite® 1/4" Input Jack



MM111

Mighty Mite® 1/4" Barrel
Input Jack



MM112

Mighty Mite® 1/4" Barrel
End Pin Input Jack

MM709

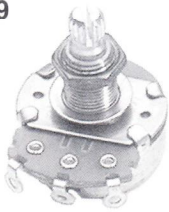

Mighty Mite® A500K
Audio Control Pot
Quarter Size

MM710



Mighty Mite® B500K
Linear Control Pot
Quarter Size

MM712



Mighty Mite® D500K
Audio Control Pot
Quarter Size

MM714



Mighty Mite® A250K
Audio Control Pot
Quarter Size

MM716



Mighty Mite® B250K
Linear Control Pot
Quarter Size

MM703

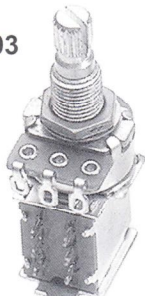

Mighty Mite®
Push-Pull
A250K Audio
(DPDT)

MM704



Mighty Mite®
Push-Pull
A500K Audio
(DPDT)

MM706

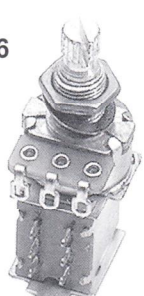

Mighty Mite®
Push-Pull
B500K Linear
(DPDT)

MM700



Mighty Mite®
A250K Audio
Short Shaft
Dime Size

MM700L



Mighty Mite®
A250K Audio
Long Shaft
Dime Size

MM701



Mighty Mite®
B250K Linear
Short Shaft
Dime Size

MM701L



Mighty Mite®
B250K Linear
Long Shaft
Dime Size

MM702

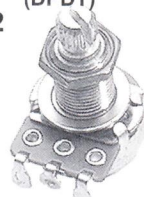

Mighty Mite®
D500K Audio
Short Shaft
Dime Size

MM708L

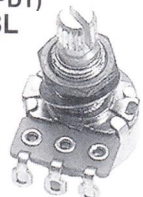

Mighty Mite®
B500K Linear
Long Shaft
Dime Size

MM708



Mighty Mite®
B500K Linear
Short Shaft
Dime Size

MM707L



Mighty Mite®
A500K Audio
Long Shaft
Dime Size

MM707



Mighty Mite®
A500K Audio
Short Shaft
Dime Size

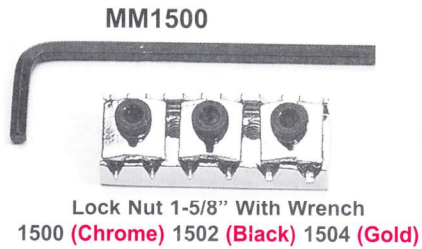

Lock Nut 1-5/8" With Wrench
1500 (Chrome) 1502 (Black) 1504 (Gold)

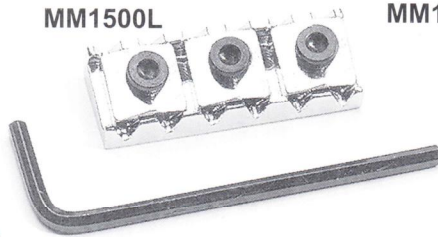

Lock Nut 1-11/16" With Wrench
1500 (Chrome) 1502 (Black) 1504 (Gold)



Roller String Tree
C (Chrm) B (Black) G (Gold)
Screws Included

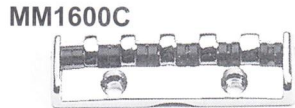

Mighty Mite® Roller Nut 1-5/8"
1500 (Chrome) 1502 (Black) 1504 (Gold)



Quick Release Strap Lock System / MM5614 (Brass)



String Retainer Bar
C (Chrm) B (Black) G (Gold)
Screws Included

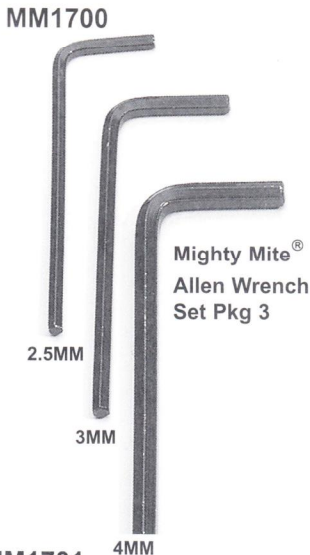

Mighty Mite®
Allen Wrench
Set Pkg 3

2.5MM

3MM

4MM



Contemporary Strap Buttons
C (Chrome) B (Black) G (Gold)



Strat® Replacement Vintage
Tremolo Saddles (Chrome Only)

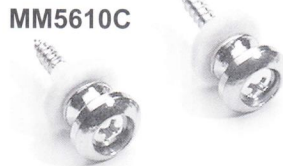

Traditional Strap Buttons
C (Chrm) B (Black) G (Gold)

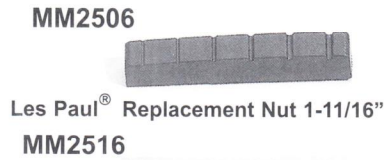

Les Paul® Replacement Nut 1-11/16"
MM2516



Knobs For Tele® 3 Way Switch
MM504 (Bik)



4MM Allen Wrench



Pickguard Screws (Pkg 100)
C (Chrm) B (Black) G (Gold)

Acoustic Replacement Nut

Knobs For 3 & 5 Way Switch
MM506 (Cream)

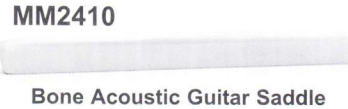

Bone Acoustic Guitar Saddle



Knobs For Strat® Style 5 Way Switch
MM515 (Cream)

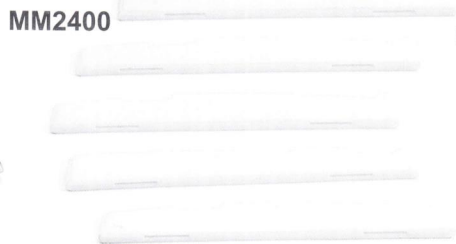

Acoustic Guitar Saddles (Pkg 5)



Knobs For Les Paul® Style Toggle Switch
MM510 (Cream)

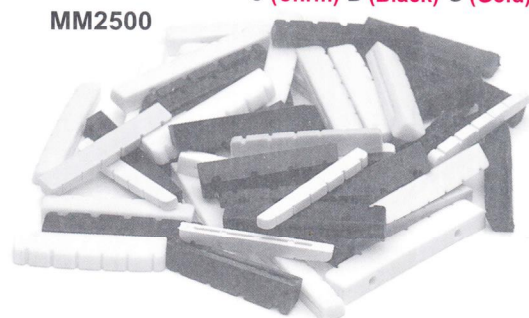

Assorted String Nuts (Pkg 55)



Bridge Pin Set Cream w/ Black Dot w/ End Pin



Bridge Pin Set Black w/ Abalone Dot w/ End Pin



Bridge Pin Set White w/ Black Dot w/ End Pin



Bridge Pin Set Black w/ White Dot w/ End Pin

Strat®, P-Bass®, J-Bass®, Tele® are trademarks of Fender Musical Instruments Corp. Mighty Mite® is not affiliated with Fender Musical Instruments Corp. Les Paul® is a trademark of Gibson Musical Instruments Co. which is not affiliated, Floyd Rose® is not affiliated, Wilkinson® is not affiliated with Mighty Mite®

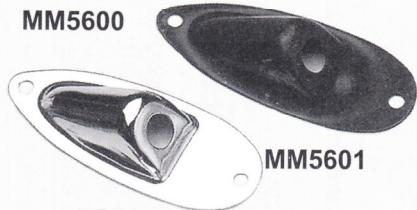

MM5600

MM5601



MM5602

Strat® Replacement Jack Plate
5600 (Black) 5601 (Chrome) 5602 (Gold)

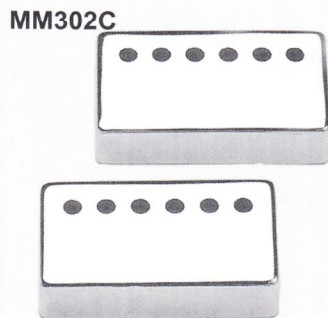

MM302C

Mighty Mite® Traditional Style
Humbucker Covers
C (Chrome) G (Gold)

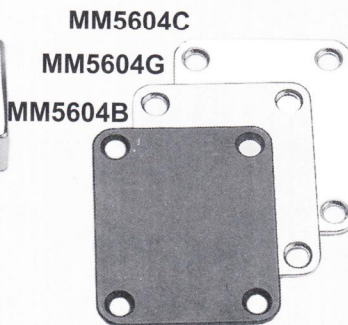

MM5604C

MM5604G

MM5604B

Mighty Mite® Neck Plates
w/ Mounting Screws
C (Chrome) B (Black) G (Gold)



MM320B

Strat® Replacement Covers
B (Black) W (White) CR (Cream)

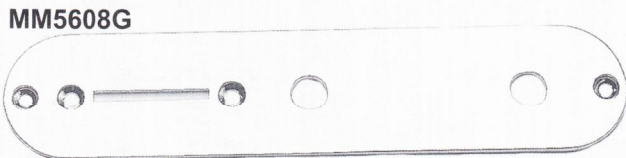

MM5608G

Tele® Replacement Control Plate
MM5608C (Chrome) MM5608G (Gold)



MM5605B MM5605G MM5605C

Tele® Replacement Jack Plate
C (Chrome) B (Black) G (Gold)



MM5606B

Les Paul® Style
Rhythm / Treble Rings

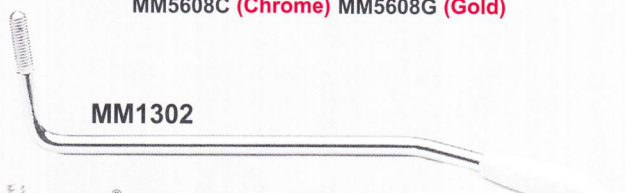

MM1302

Strat® Replacement w/ White Knob

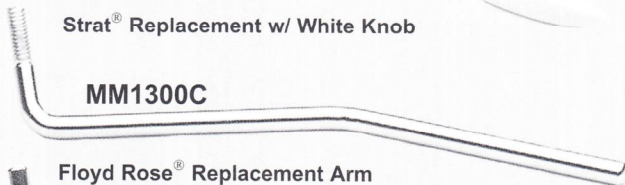

MM1300C

Floyd Rose® Replacement Arm
C (Chrome) B (Black) G (Gold)



MM1306C

Floyd Rose® II Replacement Arm
C (Chrome) B (Black) G (Gold)

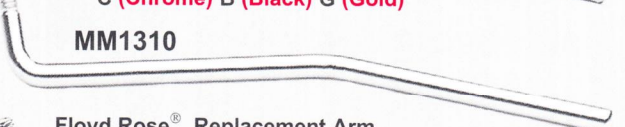

MM1310

Floyd Rose® Replacement Arm
1/4" Long (Chrome) Only

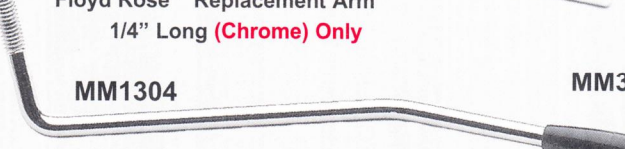

MM1304

Strat® Replacement w/ Black Knob

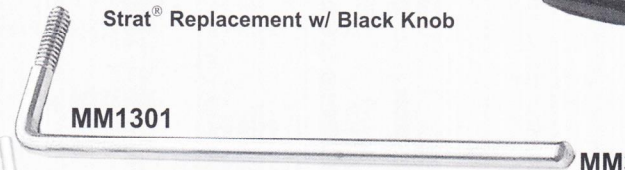

MM1301

Strat® Vintage Replacement Chrome

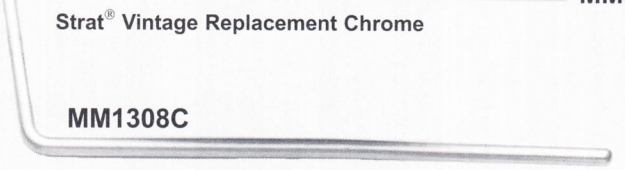

MM1308C

Wilkinson® Replacement Arm
C (Chrome) B (Black) G (Gold)

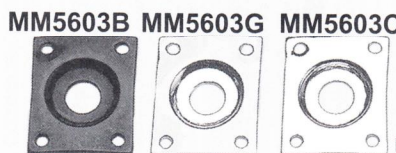

MM5603B MM5603G MM5603C

Les Paul® Style Jack Plate
C (Chrome) B (Black) G (Gold)



MM309C

Mighty Mite® Metal Mounting Rings w/
Screws & Springs
C (Chrome) B (Black) G (Gold) SC
(Smoked Chrome)

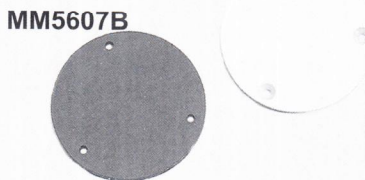

MM5607B

Les Paul® Toggle Plates
B (Black) CR (Cream)



MM5500

Strat® Replacement Back Plate / (5501 Cream)

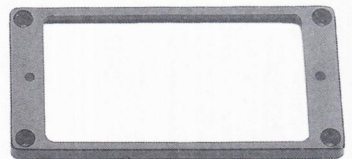

MM300B/T

Mighty Mite® Pickup Mounting Rings
(2 Pkg) w/ Screws & Springs / TALL
B (Black) CR (Cream)

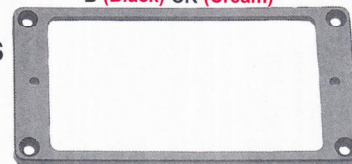

MM300B/S

Mighty Mite® Pickup Mounting Rings
(2 Pkg) w/ Screws & Springs
B (Black) CR (Cream)



MM5502

Les Paul® Replacement Back Plate
5502 (Black) 5503 (Cream)

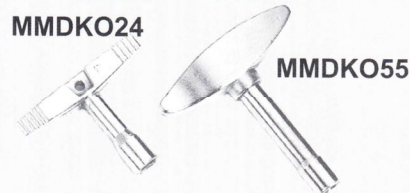

MMDKO24

MMDKO55

Mighty Mite® Drum Keys (Pkg 2)

Strat®, P-Bass®, J-Bass®, Tele® are trademarks of Fender Musical Instruments Corp. Mighty Mite® is not affiliated with Fender Musical Instruments Corp.
Les Paul® is a trademark of Gibson Musical Instruments Co. which is not affiliated, Floyd Rose® is not affiliated, Wilkinson® is not affiliated with Mighty Mite®

MMRK2

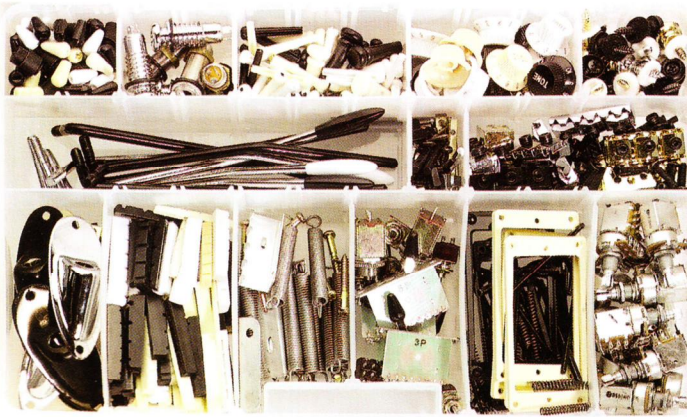

Switch Knobs 10-BK504 10-BK514 10-BK506 10-BK515 10-BK508 10-BK516 10-BK510 10-BK534	Input Jacks 3-BK111 3-BK112	Bridge Pins & End Pins 10-BK514 / 3-BK2300E 10-BK515 / 3-BK2302E 10-BK516 / 3-BK2304E	Strat®Knobs 2-BK914 2-BK916 2-BK917 2-BK918 2-BK919 2-BK920	Strap Button 4-BK5610B 4-BK5610C 4-BK5610G 4-BK5612B 4-BK5612C 4-BK5612G
Tremolo Arms 2-BK1302 / 4-BK1300 / 2-BK1304		Retainer Bar / Tree's 2-BK1506B 5-BK1508B 2-BK1506C 5-BK1508C 1-BK1506G 3-BK1508G		Locking Nuts 2-BK1500 2-BK1502L 2-BK1500L 2-BK1504 2-BK1502 2-BK1504L
Strat Recessed Jack Plates 2-BK5600-BLK 2-BK5601-CHRM 2-BK5602-GLD	Assorted Nuts BK2500 / 55 Pkg Acoustic Saddles 15 (Pkg)	Hooks Springs Screws 3-BK4200 15-BK4300 10-BK4400	Switches 2-BK500 2-BK503 2-BK511 2-BK518 2-BK520	Humbucker Mounting Rings 2-BK300B-S 2-BK300B-T 2-BK300CR-S 2-BK300CR-T
				Pots 2-BK700 2-BK702 2-BK703 2-BK704 2-BK706 2-BK710 2-BK712 2-BK714 30-Wash/Nut

Item	Description	Qty/RK1	Qty/RK2	Item	Description	Qty/RK1	Qty/RK2
BK111	1/4" Barrel Style Input Jack	7	3	BK1500	Locking Nut / Complete Set w/ Wrench 1-5/8" (Chrome)	5	2
BK112	1/4" Barrel Style End Pin Input Jack	7	3	BK1500L	Locking Nut / Complete Set w/ Wrench 1-11/16" (Chrome)	5	2
BK300B-S	Short Plastic Humbucker Pickup Ring (Black)	5	2	BK1502	Locking Nut / Complete Set w/ Wrench 1-5/8" (Black)	5	2
BK300B-T	Tall Plastic Humbucker Pickup Ring (Black)	5	2	BK1502L	Locking Nut / Complete Set w/ Wrench 1-11/16" (Black)	5	2
BK300CR-S	Short Plastic Humbucker Pickup Ring (Cream)	5	2	BK1504	Locking Nut / Complete Set w/ Wrench 1-5/8" (Gold)	5	2
BK300CR-T	Tall Plastic Humbucker Pickup Ring (Cream)	5	2	BK1504L	Locking Nut / Complete Set w/ Wrench 1-11/16" (Gold)	5	2
BK500	3 Position Toggle Switch (Black Knob)	5	2	BK1506C	String Retainer Bar (Chrome)	5	2
BK503	5 Way Switch (Black Knob)	5	2	BK1506B	String Retainer Bar (Black)	5	2
BK504	Knobs For 3 & 5 Way Switch (Black)	22	10	BK1506G	String Retainer Bar (Gold)	3	1
BK506	Knobs For 3 & 5 Way Switch (Cream)	22	10	BK1508C	Roller String Tree (Chrome)	11	5
BK508	Knobs For 3 Position Toggle Switch (Black)	22	10	BK1508B	Roller String Tree (Black)	11	5
BK510	Knobs For 3 Position Toggle Switch (Cream)	22	10	BK1508G	Roller String Tree (Gold)	5	3
BK511	3 Way Switch (Black Knob)	5	2	BK2300B	Bridge Pin / White w/ Black Dot	22	10
BK514	Knobs For 5 Way Switch (Black)	22	10	BK2300E	End Pin / White w/ Black Dot	7	3
BK515	Knobs For 5 Way Switch (Cream)	22	10	BK2302B	Bridge Pin / Black w/ White Dot	22	10
BK516	Knobs For 5 Way Switch (White)	22	10	BK2302E	End Pin / Black w/ White Dot	7	3
BK518	Mini Toggle Switch / 3 Single Terminal System	5	2	BK2304B	Bridge Pin / Cream w/ Black Dot	22	10
BK520	Mini Toggle Switch / 3 Dual Terminal System	5	2	BK2304E	End Pin / Cream w/ Black Dot	7	3
BK534	Knobs For 3 Way Switch (Black)	22	10	BK2400	Acoustic Guitar Saddle (Cream)	33	15
BK700	Control Pot / A250K Audio Short Shaft Dime Size	5	2	BK2500	Assorted String Nut Package / 55 Pcs	110 / PCS	55 / PCS
BK702	Control Pot / D500K Audio Short Shaft Dime Size	5	2	BK4200	Tremolo Spring Claw Hook	7	3
BK703	Control Pot / A250K Audio Push Pull	5	2	BK4300	Tremolo Springs	33	15
BK704	Control Pot / A500K Audio Push Pull	5	2	BK4400	Tremolo Spring Claw Hook Screw	22	10
BK706	Control Pot / B500K Linear Push Pull	5	2	BK5600	Strat® Replacement Recessed Jack Plate (Black)	5	2
BK710	Control Pot / B500K Linear Quarter Size	5	2	BK5601	Strat® Replacement Recessed Jack Plate (Chrome)	5	2
BK712	Control Pot / D500K Audio Quarter Size	5	2	BK5602	Strat® Replacement Recessed Jack Plate (Gold)	5	2
BK714	Control Pot / A250K Audio Quarter Size	5	2	BK5603B	Les Paul® Replacement Jack Plate (Black)	5	2
BK914	Control Knob / Strat® Replacement / Volume (Black)	9	4	BK5603C	Les Paul® Replacement Jack Plate (Chrome)	5	2
BK916	Control Knob / Strat® Replacement / Volume (White)	9	4	BK5603G	Les Paul® Replacement Jack Plate (Gold)	5	2
BK917	Control Knob / Strat® Replacement / Volume (Cream)	9	4	BK5610B	Strap Button / Traditional Style (Black)	9	4
BK918	Control Knob / Strat® Replacement / Tone (Black)	9	4	BK5610C	Strap Button / Traditional Style (Chrome)	9	4
BK919	Control Knob / Strat® Replacement / Tone (Cream)	9	4	BK5610G	Strap Button / Traditional Style (Gold)	9	4
BK920	Control Knob / Strat® Replacement / Tone (White)	9	4	BK5612B	Strap Button / Contemporary Style (Black)	9	4
BK1300C	Tremolo Arm / Floyd Rose® Replacement (Chrome)	9	4	BK5612C	Strap Button / Contemporary Style (Chrome)	9	4
BK1302	Tremolo Arm / Strat® Replacement / (White Knob)	5	2	BK5612G	Strap Button / Contemporary Style (Gold)	9	4
BK1304	Tremolo Arm / Strat® Replacement / (Black Knob)	5	2				

NOTE: RK1, Control Pots Come With 60 pcs Of Extra Washers & Nuts
RK2, Control Pots Come With 30 pcs Of Extra Washers & Nuts

MM2500 String Nut Package

- 5- Acoustic Style 1-11/16" (White)
- 5- Les Paul® Style 1-11/16" (Cream)
- 6- Acoustic Style 1-11/16" (Cream)
- 5- Les Paul® Style 1-11/16" (White)
- 4- Classical Style 2" (White)
- 5- Acoustic Style 1-11/16" (Black)
- 6- Les Paul® Style 1-11/16" (Black)
- 4- 5 String Bass Style 1-3/4" (Black)
- 5- 4 String Bass Style 1-11/16" (Black)
- 5- 4 String Bass Thin Style 43X3T (Black)
- 5- Electric Guitar Style 43X3T (Cream)

NOTE: RK1 Packaged With 2 MM2500 Packages

MMSK1



Neck Plate Screws 50-BK7100C 50-BK7100B 25-BK7100G	Humbucker Pickup Screws 100-BK7700B 100-BK7700C 25-BK7700G	Strap Button Screws 50-BK7400B	Strap Button Screws 50-BK7400C
	Machine Head Screws 100-BK730B 100-BK730C	Guitar Pickup Screws 100-BK7500B	Strap Button Screws 25-BK7400G
Pickguard Screws 100-BK7000B 100-BK7000C 100-BK7000G	Humbucker Ring Screws 100-BK7200B-SHRT 100-BK7200B-TALL 100-BK7200C-SHRT 100-BK7200C-TALL	Humbucker Ring Springs 50-BK7800	Bass Guitar Pickup Screws 100-BK7600C 100-BK7600B

BCL1



Heavy Duty Storage Areas Give You Endless Storage Possibilities With Re-Enforced Zippers To Handle The Wear & Tear Of The Road.



Mighty Mite® Lite Weight Case

The Strength And Durability Of A Case, With The Storage Of A Bag Wrapped Up In One. Ultimate Storage For Your Guitar And Accessories.



The Buddha Rope / BR1

Bill "The Buddha" Dickens created this unconventional string-dampening practice aid. The Buddha Rope is an accelerated technique builder, that you slide under your strings to raise your action and enhance the string tension. Comes with a complete instructional guide that will increase your chops and finger strength.

All Mighty Mite® Bags Come With Our Padded Neck Rest

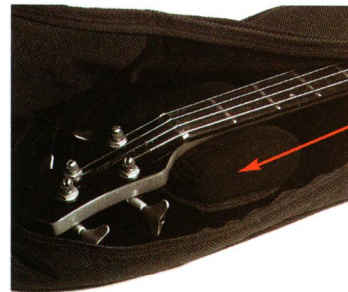

Bass Guitar

Electric / Acoustic & Bass Guitar



BCL1

Electric Guitar



BCE3

Acoustic Guitar



BCW2



BCB4



Mighty Mite® Pre-Wired Pickguard Assemblies
 Our legendary pickups are now available pre-wired. Experience Mighty Mite Tone.

- MM400W - SSS / WHITE WITH WHITE HARDWARE / STRAT®
- MM400B - SSS / BLACK WITH BLACK HARDWARE / STRAT®
- MM400TS - SSS / TORTOISE WITH BLACK HARDWARE / STRAT®
- MM405W - SSH / WHITE WITH WHITE HARDWARE / STRAT®
- MM405B - SSH / BLACK WITH BLACK HARDWARE / STRAT®
- MM405TS - SSH / TORTOISE WITH BLACK HARDWARE / STRAT®
- MM410W - PJ STYLE / WHITE WITH WHITE HARDWARE / P-BASS®
- MM410B - PJ STYLE / BLACK WITH BLACK HARDWARE / P-BASS®
- MM410TS - PJ STYLE / TORTOISE WITH BLACK HARDWARE / P-BASS®



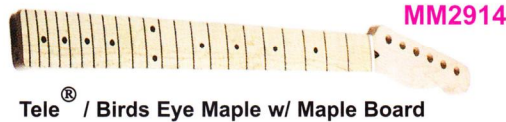

Tele[®] / Birds Eye Maple w/ Maple Board

MM2914

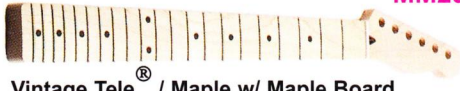

Vintage Tele[®] / Maple w/ Maple Board

MM2905V



Tele[®] / Maple w/ Maple Board

MM2904



Tele[®] / Maple w/ Maple Board

MM2905

Mighty Mite[®] Fender[®] Licensed Replacement necks are made from the finest Northern Michigan & Canadian Hard Rock Maple. Completely shaped, fretted, inlaid and finished with a clear satin lacquer. Mighty Mite necks include truss rod.

Specifications

Type	Radius	Frets	Nut Width	Thickness At 1st	Thickness At 12th
Strat [®]	9.5"	22 / Medium Jumbo	1.7"	.77"	.85"
V-Strat [®]	9.5"	22 / Vintage Frets	1.7"	.85"	.88"
P-Bass [®]	15"	20 / Medium Jumbo	1.5"	.84"	.9"
J-Bass [®]	15"	20 / Medium Jumbo	1.5"	.84"	.9"
Tele [®]	9.5"	21 / Medium Jumbo	1.7"	.81"	.85"
V-Tele [®]	9.5"	21 / Vintage Frets	1.7"	.85"	.85"
Les Paul [®]	14"	22 / Jumbo	1.7"	.84"	.9"
Strat [®] (Paddle)	9.5"	22 / Medium Jumbo	1.7"	.84"	.88"
Strat [®] (Graphite)	15"	22 / Medium Jumbo	1.7"	.8"	.84"
P-Bass [®] 5 String	15"	20 / Medium Jumbo	.2"	.85"	.93"



P-Bass[®] / Maple w/ Rosewood Board

MM2906



P-Bass[®] / Maple w/ Maple Board

MM2907



P-Bass[®] / Fretless w/ Ebonal Board

MM2919



J-Bass[®] / Maple w/ Rosewood Board

MM2908



J-Bass[®] / Maple w/ Maple Board

MM2909



P-Bass[®] / 5 String / Maple w/ Rosewood Board

MM2920



NECKS



Strat[®] / Maple / w/ Rosewood Board

MM2900



Strat[®] / Maple / w/ Rosewood Board Left Handed

MM2900L

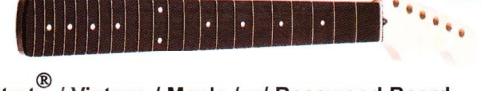

Strat[®] / Vintage / Maple / w/ Rosewood Board Vintage Fret Wire / V Head Stock

MM2900V



Strat[®] / Birds Eye Maple / w/ Rosewood Board

MM2901

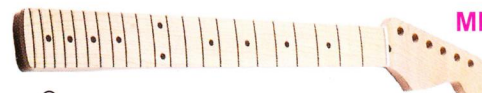

Strat[®] / Maple / w/ Maple Board

MM2902



Strat[®] / Maple / w/ Maple Board Left Handed

MM2902L



Strat[®] / Vintage / Maple / w/ Maple Board Vintage Fret Wire / V Head Stock

MM2902V



Strat[®] / Birds Eye Maple / w/ Maple Board

MM2903



Strat[®] / Maple / w/ Ebony Board

MM2910



Strat[®] / Birds Eye Maple / w/ Ebony Board

MM2912



Les Paul[®] / Les Paul Style / Maple w/ Rosewood Board

MM2924



Mighty Mite[®] Custom Strat[®] Replacement Graphite / w/ Ebonal Board

MM2918



Mighty Mite[®] Custom Strat[®] Replacement Paddle Headstock / Rosewood Board / Jumbo Frets

MM2916