

WE'VE GOT ALL  
THE RIGHT PARTS!



UPGRADE TO **MIGHTY MITE** PICK-UPS & PARTS AT YOUR DEALER

3451 West Commercial Avenue • Northbrook, IL 60062 USA • Phone: 847-498-MITE • Fax: 847-498-5370  
E-mail: [mitesales@mightymite.com](mailto:mitesales@mightymite.com) • Web: [www.MIGHTYMITE.com](http://www.MIGHTYMITE.com)



Since the 1970's, Mighty Mite® has supplied quality guitar parts to some of the best luthiers in the Industry. Our pride and customer service are un-matched and Mighty Mite® Bodies & Necks are made from the finest American Ash and Canadian Maple.

We offer, P bass®, J Bass®, Strat® & Tele® replacement bodies in a wide variety of colors and styles. From Hard Tail Strats® to Rear Routed 1 Hum Charvels®, We have what you're looking for to build that custom axe. All Mighty Mite® Bodies are cut from American Swamp Ash and the Flame & Quilt Tops are a real maple veneer. You will be blown away by the warmth, tone and finish. See Chart below:

A= Ash, Sanded & Sealed  
 AF= Ash, Finished  
 AFF= Ash, Finished Flame Top  
 AFQ= Ash, Finished Quilt Top  
 AFFR= Finished Flame Top Rear Route  
 AFQR= Finished Quilt Top Rear Route  
 H= 1 Hum Charvel Style, AFFRH  
 NT= Hard Tail, 270NTAFQ-CRS  
 CRS= Cherry Sunburst  
 2TS= Two Tone Tobacco Sunburst  
 3TS= Three Tone Tobacco Sunburst  
 NAT= Natural  
 BK= Black  
 BLB= Blue Burst  
 STBL= See Through Blue  
 STBK= See Through Black  
 SFGR= Seafoam Green  
 STR= See Through Red  
 WHT= Alpine White  
 AWHT= Antique White  
 RSPRKL= Red Sparkle  
 BSPRKL= Blue Sparkle  
 SSPRKL= Silver Sparkle  
 GSPRKL= Gold Sparkle





MM2900 MM2902 MM2912 MM2910 MM2902V MM2903 MM2900V MM2902L MM2900L MM2905 MM2904 MM2905V MM2924 MM2916

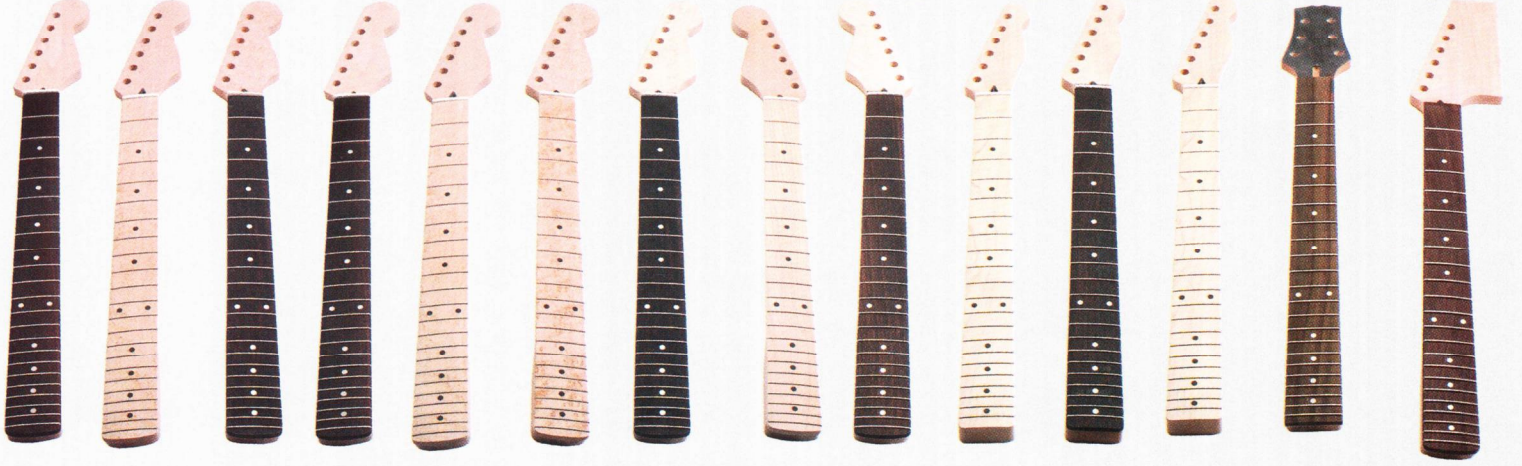

MM2920 MM2906 MM2907 MM2919 MM2908 MM2909



MM2914



Since the 1970's, Mighty Mite® has manufactured custom parts for the dreamer, You know!! The guy that can't wait to hot-rod his axe. Yes! We don't make our stuff in the USA anymore BUT we do use the finest USA wood's available and YES! we do ship our USA wood all the way to Korea, Cut It, Spray It and ship it all the way back!!! WHY???? TONE!! Other Materials from over-seas are very moist and do not resonate very well, Our stuff sounds AWESOME!! Next time you order from one of our competitors just ask them, not just where?? BUT WHAT???

The axe below is an MM2902FCR with a Compound Radius 9 1/2" to 12" and a Floyd® Nut. The body is a MM290AFFRH-STBK ONE HUM This Axe Rocks!! and YES! We Have G.A.S Too

NEW



NEW

MM2934

MM2935 = Maple  
MM2936 = Ebny

MM2902FCR

MM2900FCR = Roswd  
MM2910FCR = Ebny

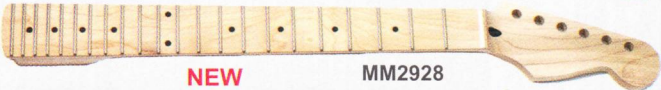

NEW

NEW

MM2928

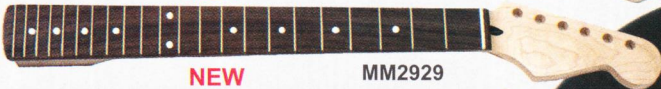

NEW

MM2929

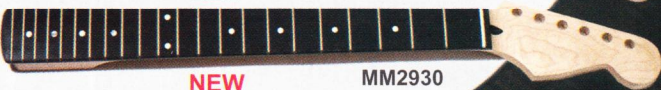

NEW

MM2930



NEW

MM2925

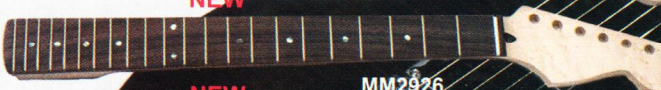

NEW

MM2926

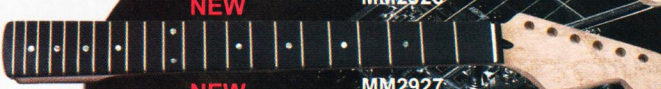

NEW

MM2927



NEW

MM2902CR

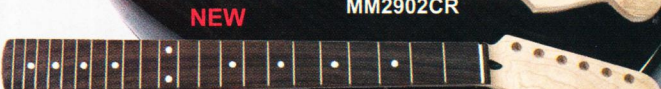

NEW

MM2900CR

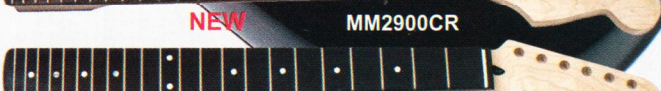

NEW

MM2910CR

Mighty Mite® has many new products available. Large Head Stock Necks & Necks with a Compound Radius. That's right folks, 9 1/2" to 12" which gives you great chords and AWESOME Leads in the same neck!! Look for the "CR" code for the new radius and "F" for the floyd nut slot.

Other Cool New Stuff!! MM2925 - MM2926 - MM2927, Jumbo Frets! 6100 Style, with Abalone Dots and Birds-Eye Maple!!

MM2921 & MM2922, Jackson® Style with 6100 Style Frets and Shark Tooth Inlay. Floyd® Nut Cut.

Please visit our web site for all specifications on All Mighty Mite® products. [www.mightymite.com](http://www.mightymite.com)



NEW

MM2921



NEW

MM2922



MMPSS-F/BK



**RESISTANCE : 5.2Kohm**  
**INDUCTANCE : 3.8H**

Single Coil Strat Replacement, Ultra Quiet with AWESOME Tone. Neck Position

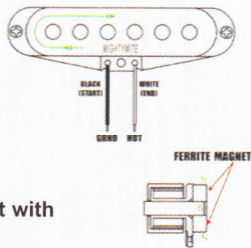

MMRSS-FM/BK



**RESISTANCE : 10.5Kohm**  
**INDUCTANCE : 4.6H**

New!! Mighty Mite® "Mighty Rail"® Pickup / Neck - Middle  
 Bare+White is GRND, Red+Blue to Coil tap,  
 Black is Hot output.

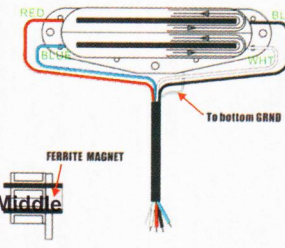

MMPSS-F/WH



**RESISTANCE : 5.2Kohm**  
**INDUCTANCE : 3.8H**

Single Coil Strat Replacement, Ultra Quiet with AWESOME Tone. Neck Position



MMRSS-FM/WH



**RESISTANCE : 10.5Kohm**  
**INDUCTANCE : 4.6H**

New!! Mighty Mite® "Mighty Rail"® Pickup / Neck - Middle  
 Bare+White is GRND, Red+Blue to Coil tap,  
 Black is Hot output.

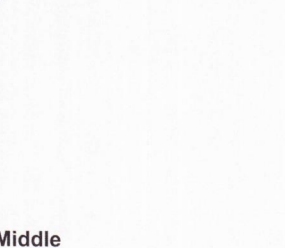

MMPSS-M/BK



**RESISTANCE : 5.2Kohm**  
**INDUCTANCE : 3.8H**

Single Coil Strat Replacement, Ultra Quiet with AWESOME Tone. Middle Position

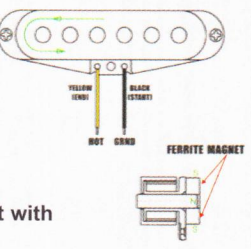

MMRSS-FM/BK



**RESISTANCE : 10.5Kohm**  
**INDUCTANCE : 4.6H**

New!! Mighty Mite® "Mighty Rail"® Pickup / Neck - Middle  
 Bare+White is GRND, Red+Blue to Coil tap,  
 Black is Hot output.

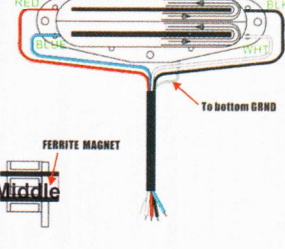

MMPSS-M/WH



**RESISTANCE : 5.2Kohm**  
**INDUCTANCE : 3.8H**

Single Coil Strat Replacement, Ultra Quiet with AWESOME Tone. Middle Position



MMRSS-FM/WH



**RESISTANCE : 10.5Kohm**  
**INDUCTANCE : 4.6H**

New!! Mighty Mite® "Mighty Rail"® Pickup / Neck - Middle  
 Bare+White is GRND, Red+Blue to Coil tap,  
 Black is Hot output.

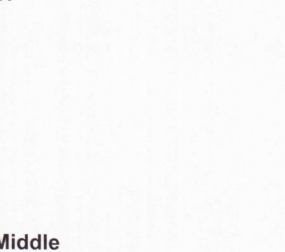

MMPSS-R/BK



**RESISTANCE : 5.2Kohm**  
**INDUCTANCE : 3.8H**

Single Coil Strat Replacement, Ultra Quiet with AWESOME Tone. Bridge Position

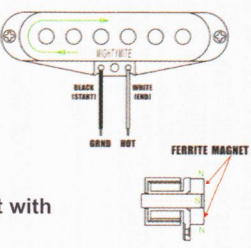

MMRSS-R/BK



**RESISTANCE : 14.3Kohm**  
**INDUCTANCE : 9.8H**

New!! Mighty Mite® "Mighty Rail"® Pickup / Neck - Middle  
 Bare+White is GRND, Red+Blue to Coil tap,  
 Black is Hot output.

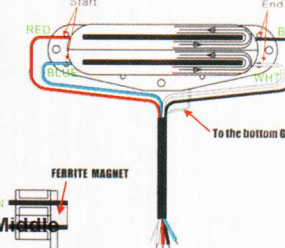

MMPSS-R/WH



**RESISTANCE : 5.2Kohm**  
**INDUCTANCE : 3.8H**

Single Coil Strat Replacement, Ultra Quiet with AWESOME Tone. Bridge Position



MMRSS-R/WH



**RESISTANCE : 14.3Kohm**  
**INDUCTANCE : 9.8H**

New!! Mighty Mite® "Mighty Rail"® Pickup / Neck - Middle  
 Bare+White is GRND, Red+Blue to Coil tap,  
 Black is Hot output.

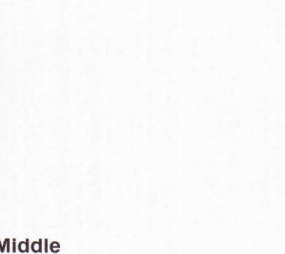





MMVPSS-F/BK

**RESISTANCE : 5.2Kohm**  
**INDUCTANCE : 2.05H**

Vintage Single Coil Strat® Replacement, Ultra Quiet w/ Alnico 5 Magnet AWESOME Vintage Tone. Neck Position

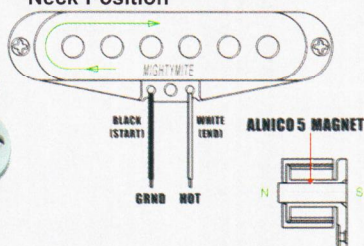

MMVPSS-F/WH

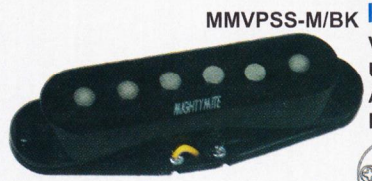

MMVPSS-M/BK

**RESISTANCE : 5.2Kohm**  
**INDUCTANCE : 2.05H**

Vintage Single Coil Strat® Replacement, Ultra Quiet w/ Alnico 5 Magnet AWESOME Vintage Tone. Middle Position, Reverse Wound

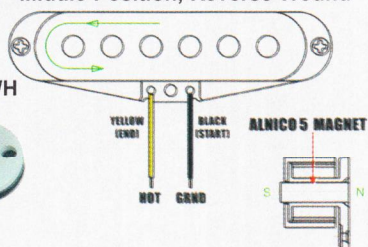

MMVPSS-M/WH



MMVPSS-R/BK

**RESISTANCE : 5.2Kohm**  
**INDUCTANCE : 2.05H**

Vintage Single Coil Strat® Replacement, Ultra Quiet w/ Alnico 5 Magnet AWESOME Vintage Tone. Bridge Position

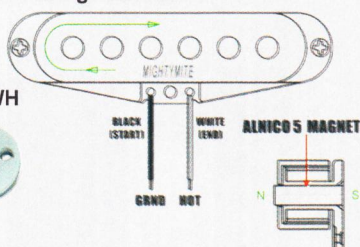

MMVPSS-R/WH



MMP90-F/BK

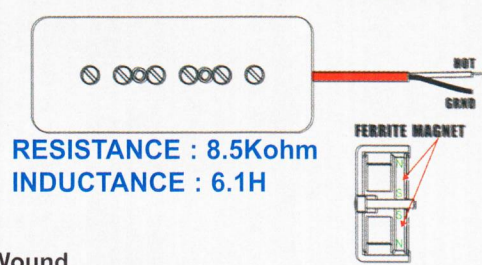

**RESISTANCE : 8.5Kohm**  
**INDUCTANCE : 6.1H**

Mighty Mite® P90 Pickups, Neck & Bridge Position Black. True P90 Tone Reverse Wound

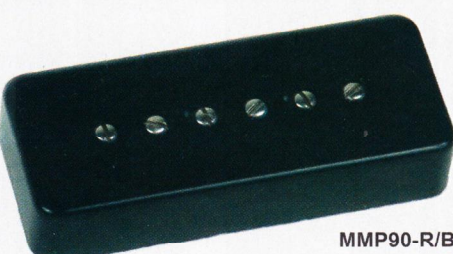

MMP90-R/BK

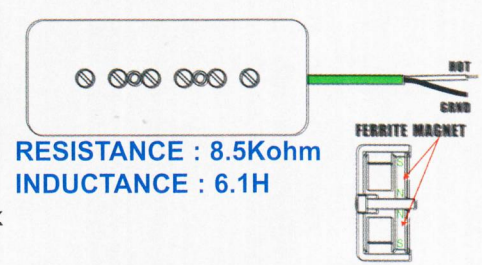

**RESISTANCE : 8.5Kohm**  
**INDUCTANCE : 6.1H**



MMTLP-F/C

**RESISTANCE : 6.8Kohm**  
**INDUCTANCE : 2.08H**

Vintage Tele® Replacement, Ultra Quiet w/ Alnico 5 Magnet AWESOME Vintage Tone. Neck Position



MMTLP-F/G

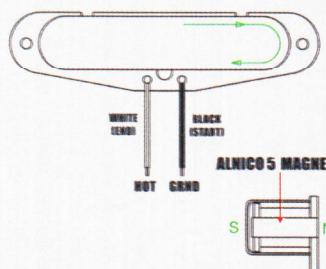

**RESISTANCE : 7.5Kohm**  
**INDUCTANCE : 2.85H**

Vintage Tele® Replacement, Ultra Quiet w/ Alnico 5 Magnet AWESOME Vintage Tone. Bridge Position



MMTLP-R

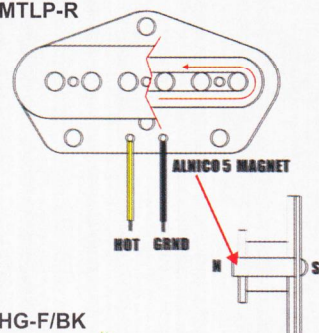

MMHG-F/BK

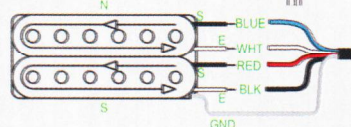

**RESISTANCE : 8.2Kohm**  
**INDUCTANCE : 4.9H**

**RESISTANCE : 17.5Kohm**  
**INDUCTANCE : 8.9H**

Mighty Mite® HG Series Humbucker Neck & Bridge Position Bare+Black is GRND, Red+Blue to Coil tap, white is Hot output. Reverse Wound

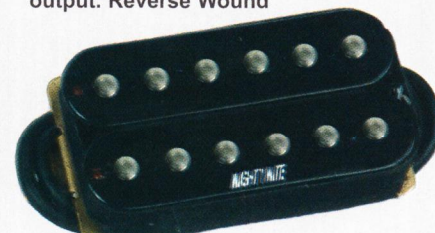

MMHG-R/BK

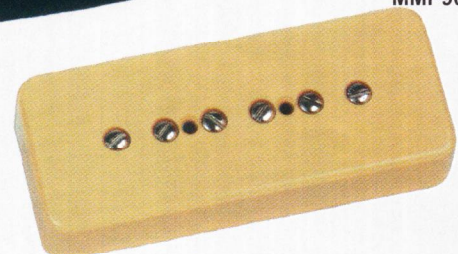
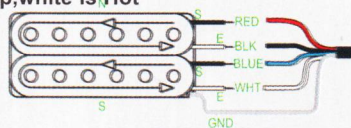

MMP90-F/CR

Mighty Mite® P90 Pickups, Neck & Bridge Position Cream. True P90 Tone Reverse Wound

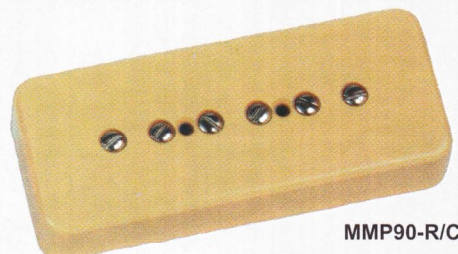

MMP90-R/CR



RESISTANCE : 11.7Kohm  
INDUCTANCE : 5.5H



MMHB-F/BK

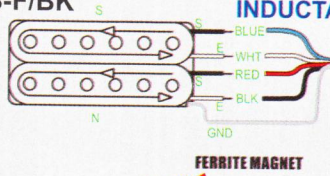

FERRITE MAGNET

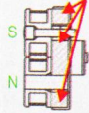

RESISTANCE : 17.8Kohm  
INDUCTANCE : 9.7H



MMHD-F/ZB

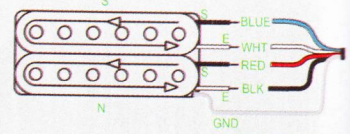

ALNICO 5 MAGNET

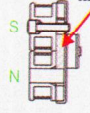

New!!Mighty Mite® "BlueBucker®" Neck & Bridge Position Pickups - Bare+White is GRND, Red+Blue to Coil tap, Black is Hot output

RESISTANCE : 18.5Kohm  
INDUCTANCE : 11.7H



MMHB-R/BK

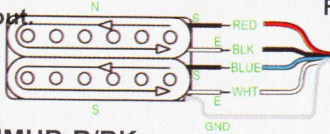

FERRITE MAGNET

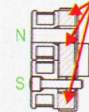

New!!Mighty Mite® "Motherbucker®" Neck & Bridge Position Pickups - Bare+White is GRND, Red+Blue to Coil tap, Black is Hot output

RESISTANCE : 22Kohm  
INDUCTANCE : 14H



MMHD-R/ZB

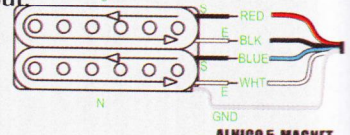

ALNICO 5 MAGNET

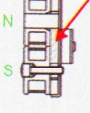

RESISTANCE : 17.8Kohm  
INDUCTANCE : 9.7H



MMHD-F/BK

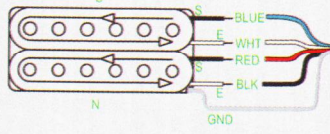

ALNICO 5 MAGNET

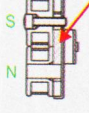

RESISTANCE : 8.2Kohm  
INDUCTANCE : 4.4H



MMHA-F/C

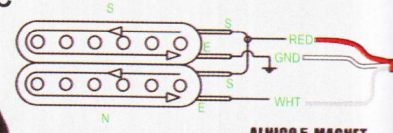

ALNICO 5 MAGNET

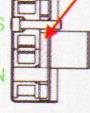

New!!Mighty Mite® "Motherbucker®" Neck & Bridge Position Pickups - Bare+White is GRND, Red+Blue to Coil tap, Black is Hot output.

RESISTANCE : 22Kohm  
INDUCTANCE : 14H



MMHD-R/BK

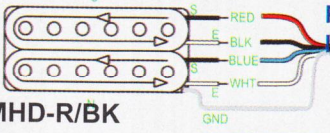

ALNICO 5 MAGNET

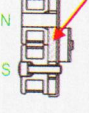

New!! Mighty Mite® "Vintage Bucker®" Neck & Bridge Position Pickups - White is Hot output, Red is coil tap function, Bare is GRND.



MMHA-R/C

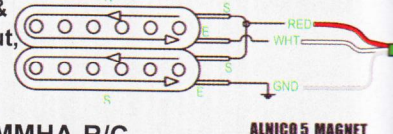

ALNICO 5 MAGNET

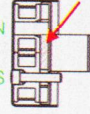

RESISTANCE : 17.8Kohm  
INDUCTANCE : 9.7H

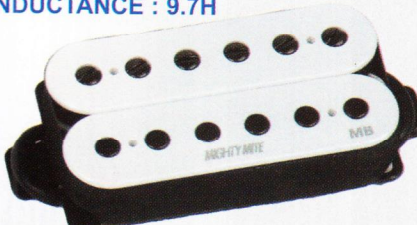

MMHD-F/WH

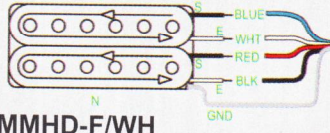

ALNICO 5 MAGNET

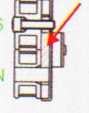

RESISTANCE : 8.2Kohm  
INDUCTANCE : 4.4H



MMHA-F/G

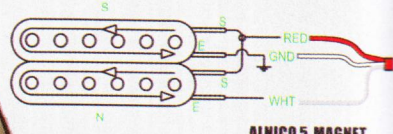

ALNICO 5 MAGNET



New!!Mighty Mite® "Motherbucker®" Neck & Bridge Position Pickups - Bare+White is GRND, Red+Blue to Coil tap, Black is Hot output

RESISTANCE : 22Kohm  
INDUCTANCE : 14H



MMHD-R/WH

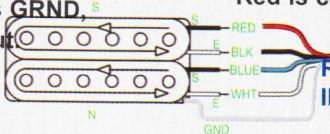

ALNICO 5 MAGNET

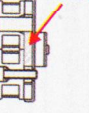

New!! Mighty Mite® "Vintage Bucker®" Neck & Bridge Position Pickups - White is Hot output, Red is coil tap function, Bare is GRND.



MMHA-R/G

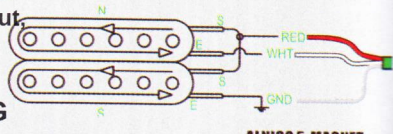

ALNICO 5 MAGNET

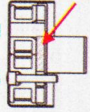



# PICKUPS / CONT

RESISTANCE : 7Kohm  
INDUCTANCE : 2.6H

MMJB-F

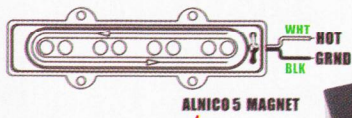

RESISTANCE : 7Kohm  
INDUCTANCE : 2.6H

MMJB-R

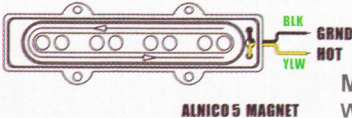

MMPB-4

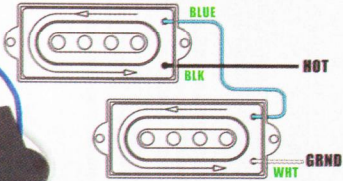
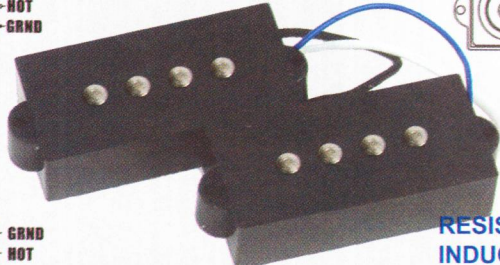

RESISTANCE : 11Kohm  
INDUCTANCE : 9.1H

Mighty Mite® "PB" Pickup  
WHITE WIRE IS HOT OUTPUT, AND CONNECT BLACK WIRE TO

RESISTANCE : 6.25Kohm  
INDUCTANCE : 4.5H

MMFR-4

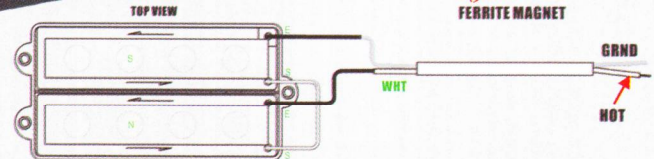

New!! Mighty Mite® "JB" Neck & Bridge Position Pickups

MMSP4-F/BK - MMSP4-R/BK

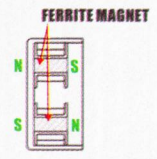
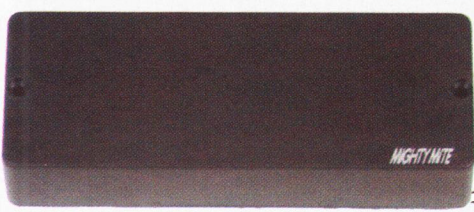

MMSP5-F/BK - MMSP5-R/BK

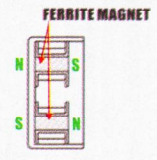
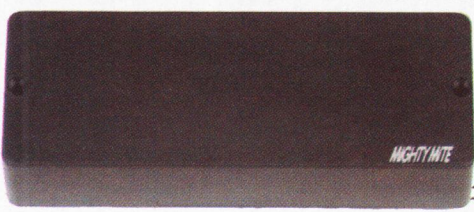

Mighty Mite® Passive & Active Bass Soap Bar Pickups for 4-5 & 6 String Bases.

The MM114 Is Recommended with our Active Pickups

MM114

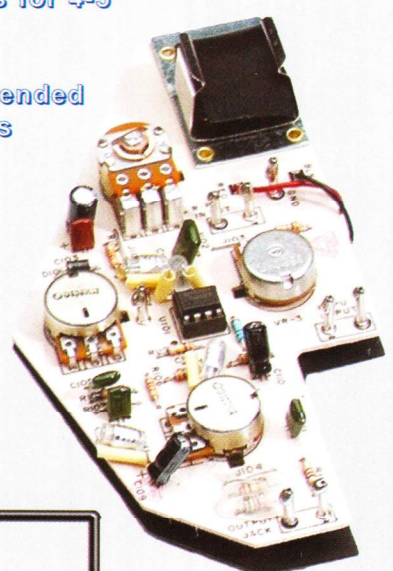

MMSA4-F/BK - MMSA4-R/BK

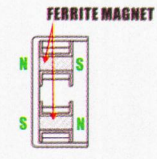
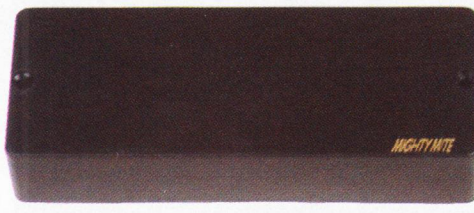

MMSA5-F/BK - MMSA5-R/BK

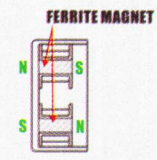
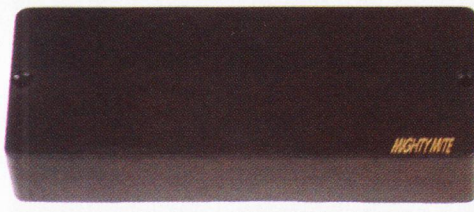

MMSA6-F/BK - MMSA6-R/BK

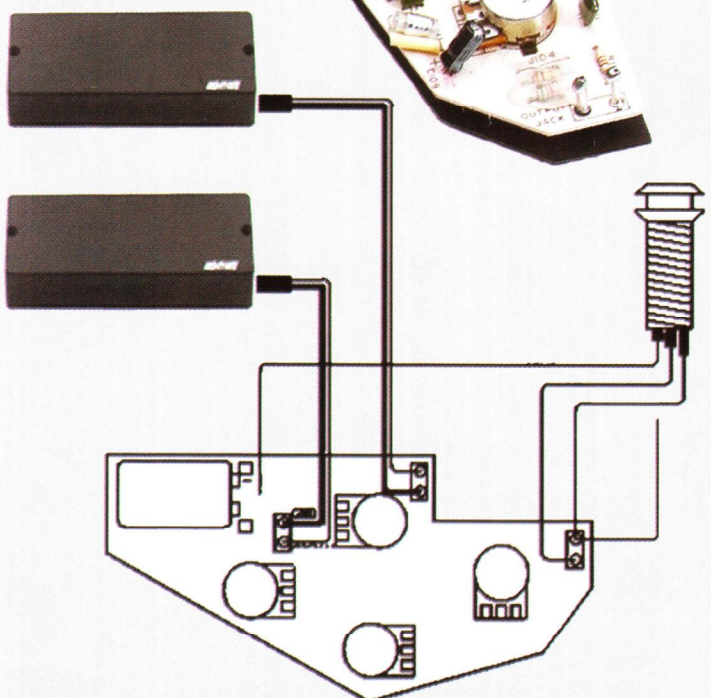
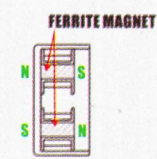
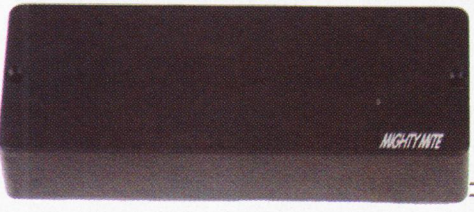



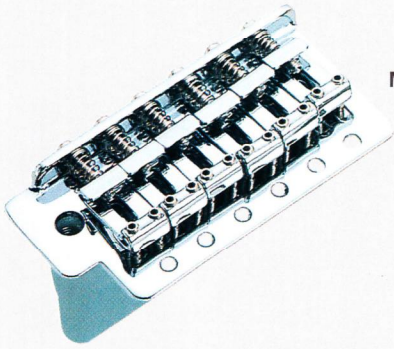
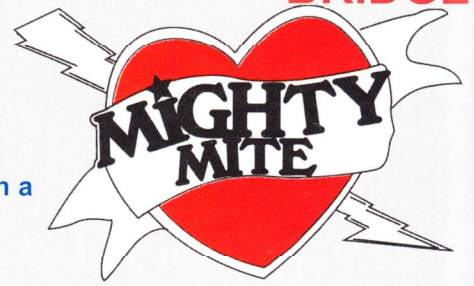

MM1100  
MM1100G = Gold

The MM1131 & MM1132 Series Tremolo's have Stainless Steel Saddles & Plate with a Brass Block and are perfect for any new build.

Stainless Steel Saddles & Plate

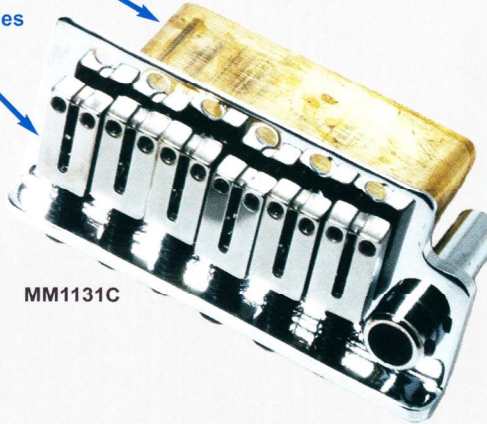

MM1131C

Check out the all new Mighty Mite® bridge line featuring our new USA-Retro fit Strat® & Tele® Style Bridges. Awesome Quality for that Hot-Rod Project you have been waiting to start.

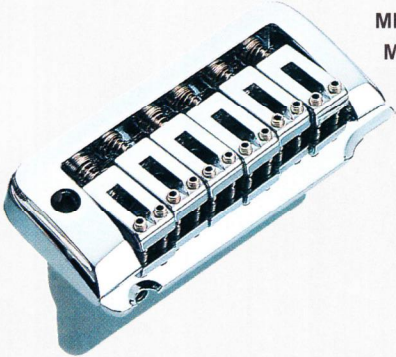

MM1112  
MM1114 = Black  
MM1116 = Gold

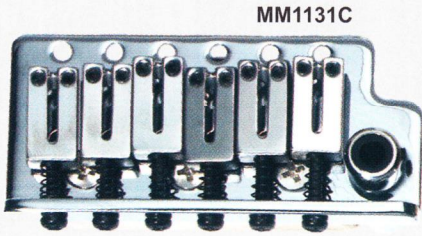

MM1131C

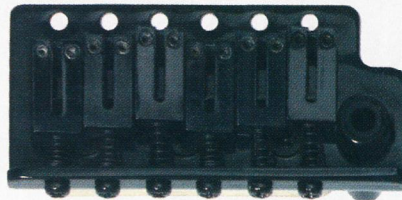

MM1131B

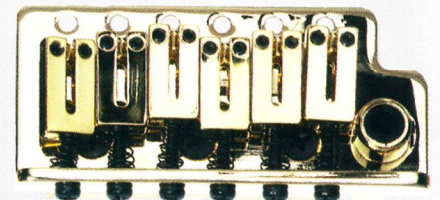

MM1131G

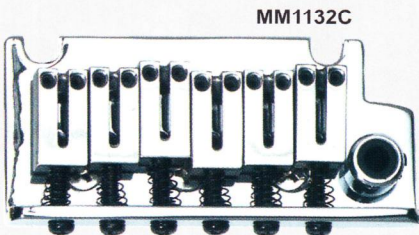

MM1132C

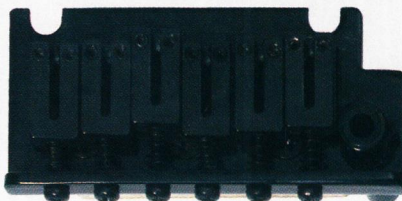

MM1132B

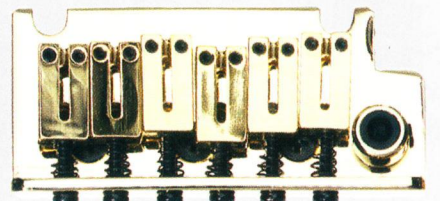

MM1132G

USA Retro-Fit

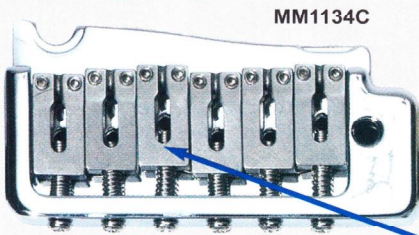

MM1134C

USA Retro-Fit

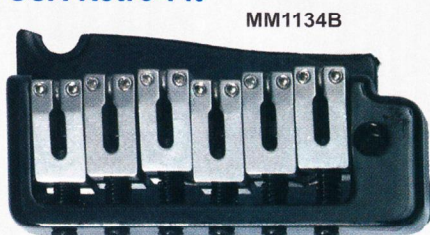

MM1134B

USA Retro-Fit

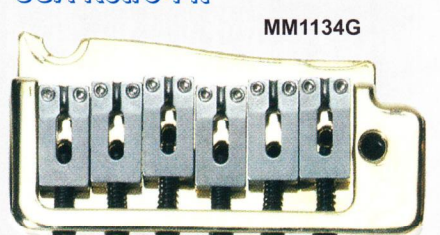

MM1134G

USA Retro-Fit

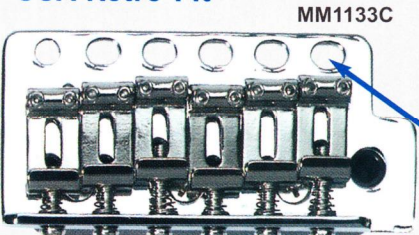

MM1133C

USA Retro-Fit

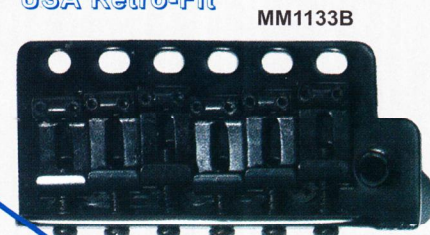

MM1133B

USA Retro-Fit

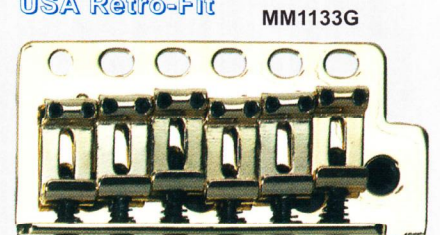

MM1133G

The MM1133 Series are USA Retro-Fit / Notice the Oval Shape Holes for perfect line-up and smoother action



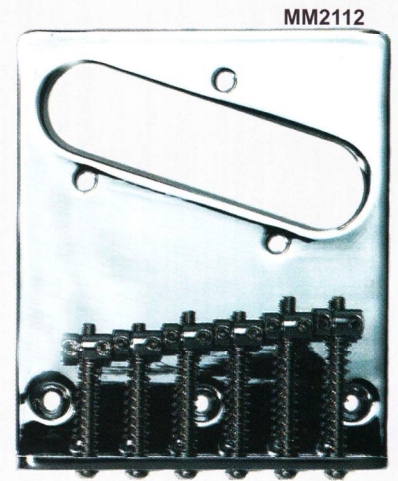
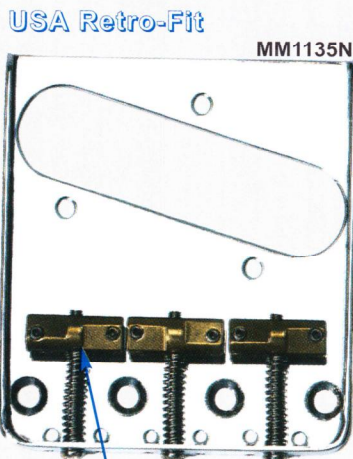
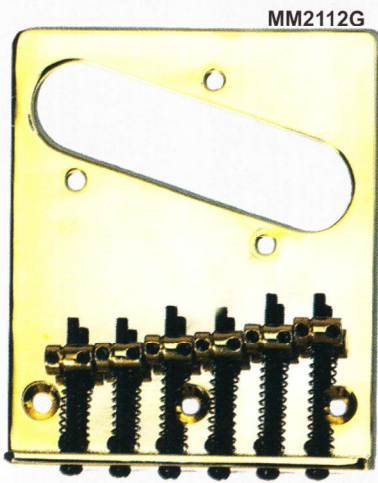

New USA Retro-Fit Tele Bridges with Brass Saddles

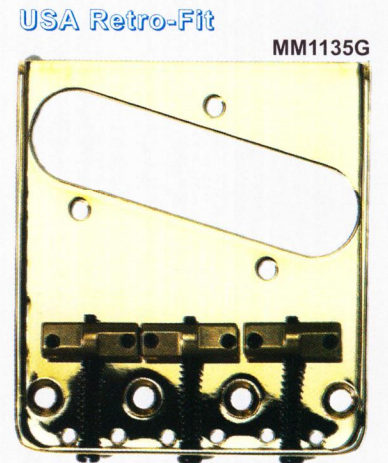
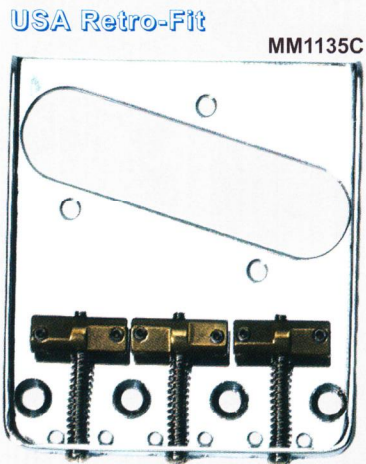

New USA Retro-Fit Gibson Style Bridges & Tails with USA Threaded Post & Screws "All Mighty Mite® Bridges Come With Hardware"

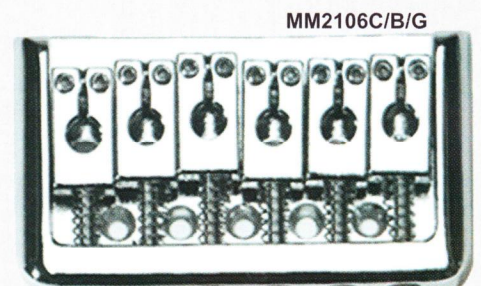
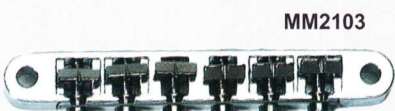
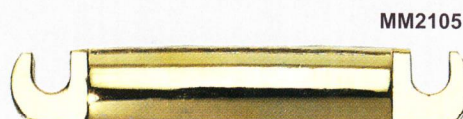
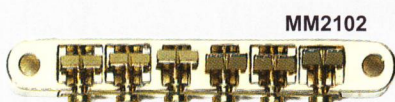
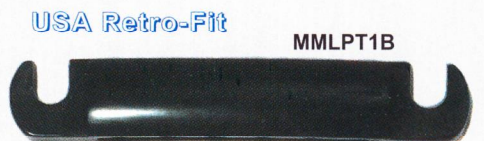
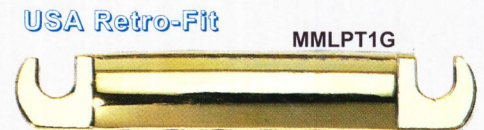
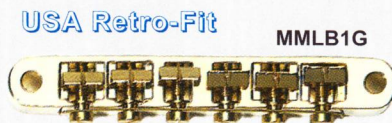
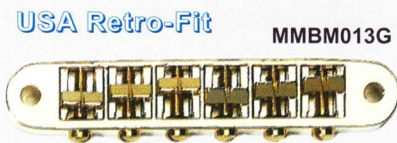



MMBL002C Floyd Rose® Style Bridge

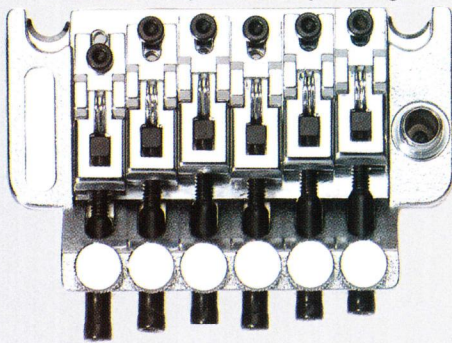

MMBL002B Floyd Rose® Style Bridge

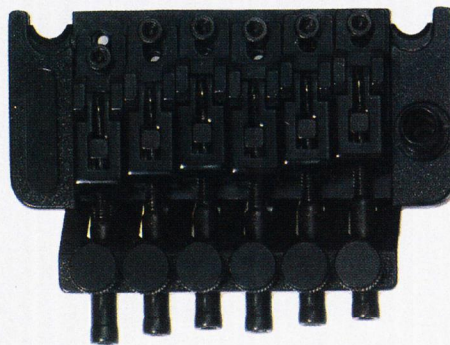

MMBL002G Floyd Rose® Style Bridge

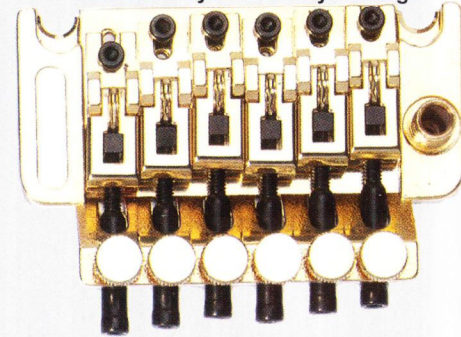

Mighty Mite® Floyd Rose® Replacement Parts

Part No.	Description	Ref No.
MM3000C	Base Plate (Chrome)	1
MM3000G	Base Plate (Gold)	1
MM3000B	Base Plate (Black)	1
MM3100	Fine Tuner Adjustment Spring	2
MM3200	Spring Holder Plate	3
MM3300	Tremolo Block / & Locking Screw	4/5
MM3500	Saddle Lock Down Screw (Pkg 6)	6
MM3600	String Holder Block (Pkg 6)	7
MM3700C	Bridge Saddle 1 & 6 (Chrome)	8
MM3700G	Bridge Saddle 1 & 6 (Gold)	8
MM3700B	Bridge Saddle 1 & 6 (Black)	8
MM3701C	Bridge Saddle 2 & 5 (Chrome)	8
MM3701G	Bridge Saddle 2 & 5 (Gold)	8
MM3701B	Bridge Saddle 2 & 5 (Black)	8
MM3702C	Bridge Saddle 3 & 4 (Chrome)	8
MM3702G	Bridge Saddle 3 & 4 (Gold)	8
MM3702B	Bridge Saddle 3 & 4 (Black)	8
MM3800	Fine Tuner Screw (Pkg 6)	9
MM3900	String Holder Locking Bolt (Pkg 2)	10
MM4000	Stud & Stud Insert	11
MM4100	Tremolo Arm Bushing G/B/C	14
MM4100	Key Washer	15
MM4100	Bottom Washer	16
MM4100	Tremolo Arm Lock Nut G/B/C	17
MM4200	Spring Claw Hook	18
MM4300	Tremolo Springs (Pkg 6)	19
MM4400	Tremolo Claw Hook Screw (Pkg 10)	20

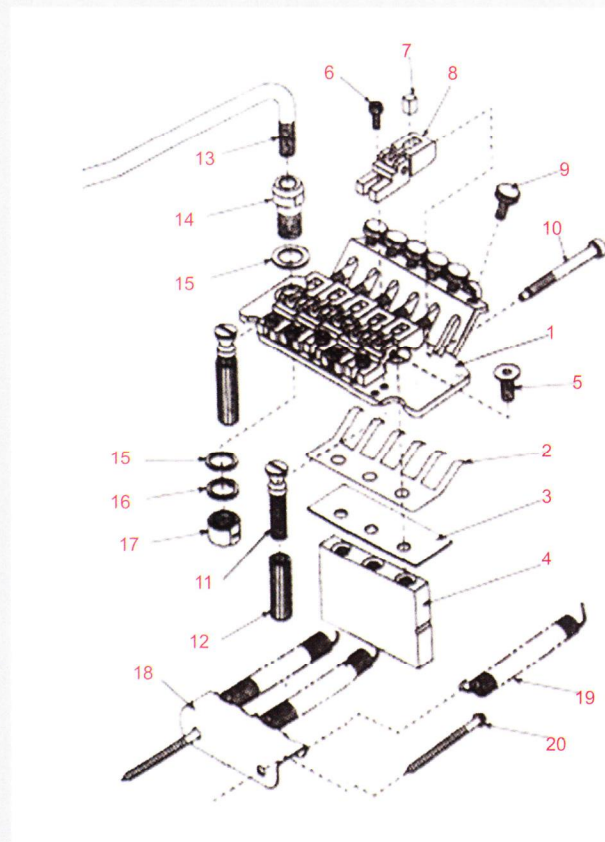

Original Floyd® Style Arms



Strat® Style Arms

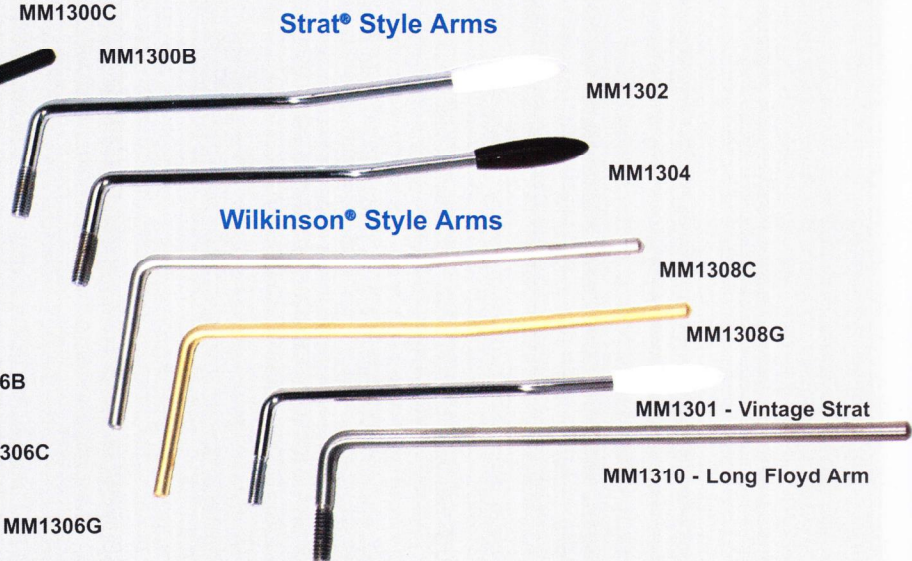



MM1204G

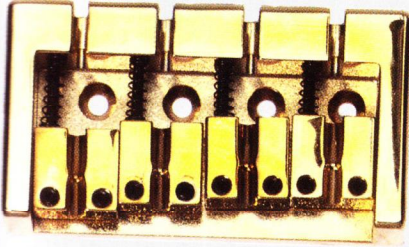

MM1204C

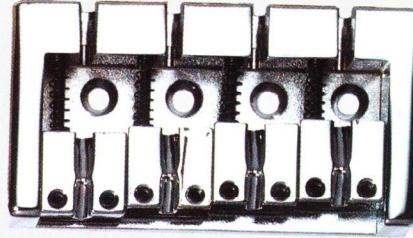

MM1204B

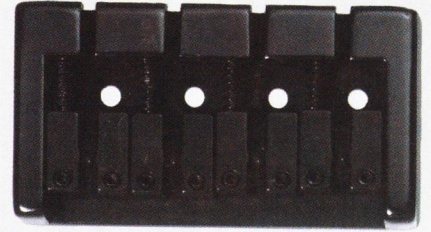

Mighty Mite® 4 string bass bridge  
Solid brass construction provides superior tone, warmth and sustain.

Mighty Mite® 4 string bass bridge  
Solid brass construction provides superior tone, warmth and sustain.

Mighty Mite® 4 string bass bridge  
Solid brass construction provides superior tone, warmth and sustain.

MM1205G

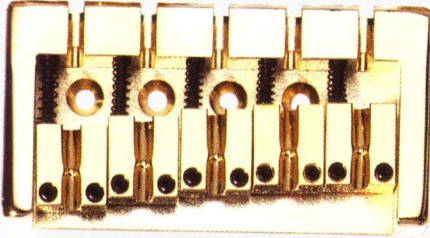

MM1205C

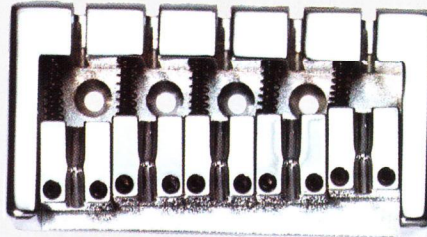

MM1205B

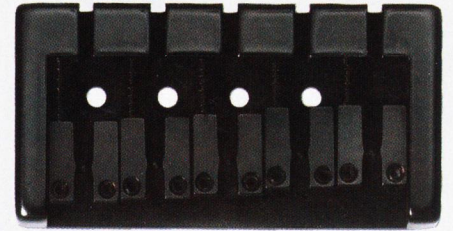

Mighty Mite® 5 string bass bridge  
Solid brass construction provides superior tone, warmth and sustain.

Mighty Mite® 5 string bass bridge  
Solid brass construction provides superior tone, warmth and sustain.

Mighty Mite® 5 string bass bridge  
Solid brass construction provides superior tone, warmth and sustain.

MM1206G

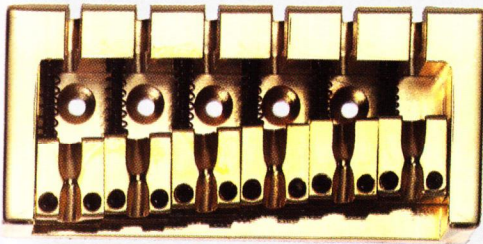

Mighty Mite® Offers Solid Brass Bass Bridges in 4-5 & 6 String Versions.

MM1206B

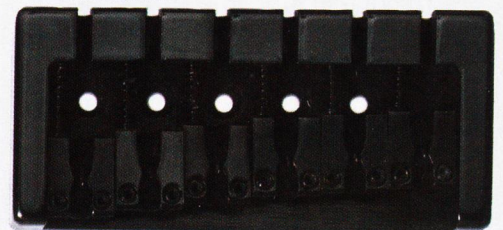

Mighty Mite® 6 string bass bridge  
Solid brass construction provides superior tone, warmth and sustain.



Mighty Mite® 6 string bass bridge  
Solid brass construction provides superior tone, warmth and sustain.

MM1110

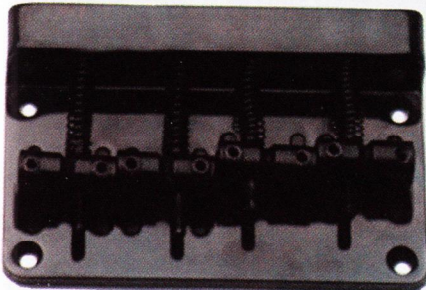

New!! Mighty Mite® 12MM Deluxe Gig Bags with a Padded Neck Rest



MM1115

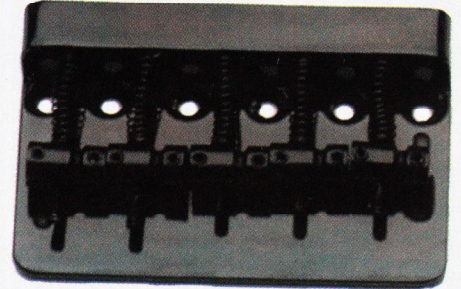

Mighty Mite® 4 String PBass® Style bass Bridge with adjustable saddle height and intonation.

Available in Black or Chrome

Mighty Mite® 5 String Bass Bridge with adjustable saddle height and intonation

Available in Black or Chrome

- MM12BE - Electric
- MM12BB - Bass
- MM12BA - Acoustic
- MM12BC - Grand Concert



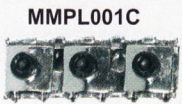

Top Mount

Bottom Mount



MM1508C / G / B

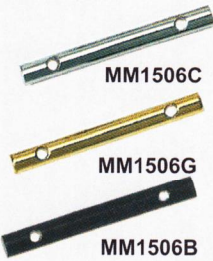
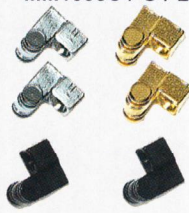

MMHS001C



MMHS001G

MMHS001B

MM5612C



MM5610C



MM1600C



MM1600G



MM1600B



MM1700 Set of 3 2.5MM / 3MM / 4MM

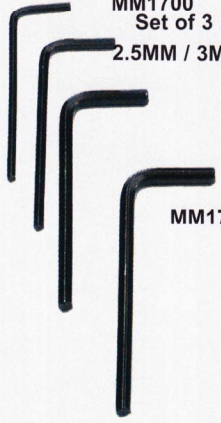

MM1701

New!! MMS501 Strap Locks



Buttons Are Dunlop Compatible



MM5613  
MM5614 - Brass

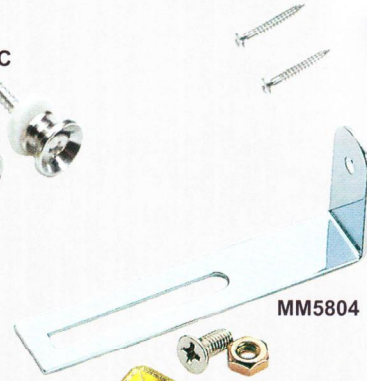

MM5804

MM5805

MM502C  
USA Retro-Fit



MM502G  
USA Retro-Fit



MM502B  
USA Retro-Fit



MM507W  
USA Retro-Fit



MM507CR  
USA Retro-Fit



MM507BK  
USA Retro-Fit



43MM  
MMPL002C



43MM  
MMPL002CBM



MMPL002G



MMPL002GBM

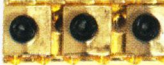

MMPL002B



MMPL002BBM



Top Mount

Bottom Mount



100 Pcs Of Pickguard Screws

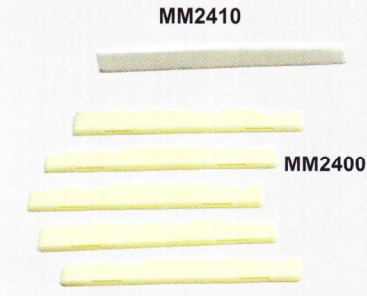

MM2410

MM2400

MM2516



MM4300

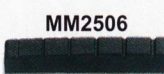

MM2506

MM535C



MM535G



MM535B



MM2300



MM2302



MM2304



MM2500 55 Pcs Of Assorted Nuts



MM2306



MM7000C / G / B



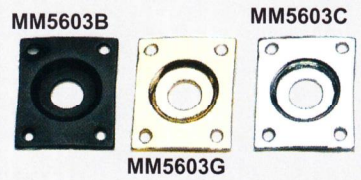
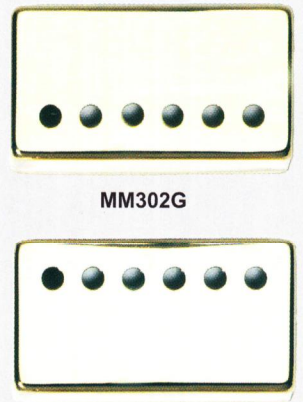
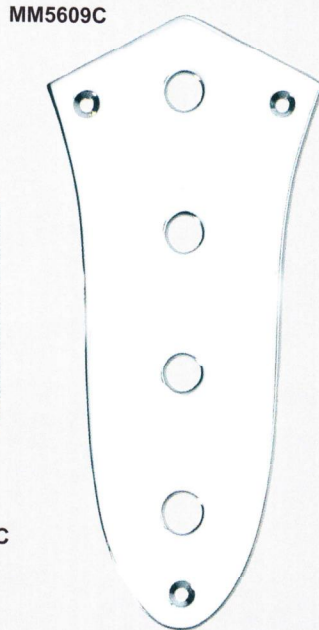
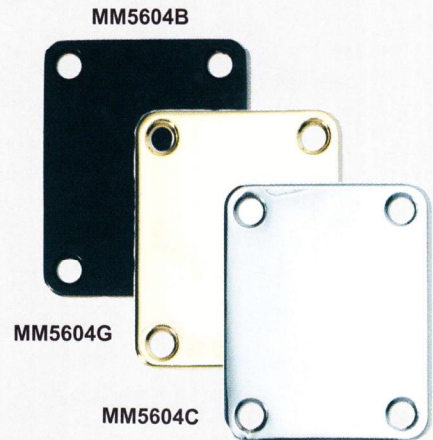
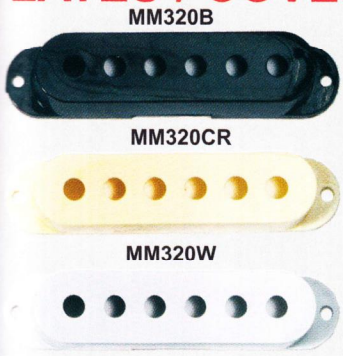

USA Retro-Fit



New USA Retro-Fit Gibson® Style Pickup Metal Rings, Fits All USA Les Pauls®. MM935G is Tall for the Bridge and MM933 is the Short for the Neck

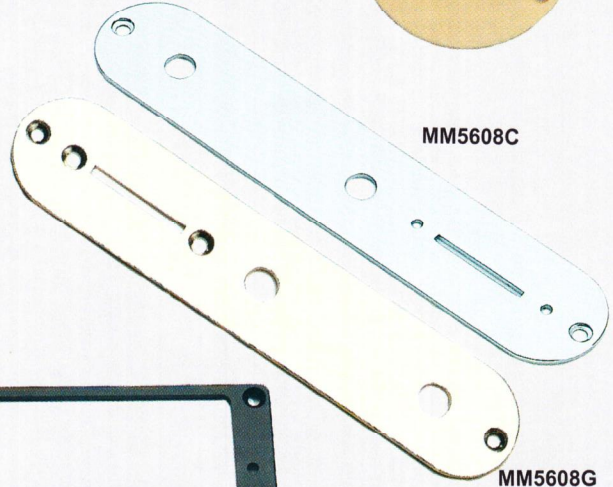
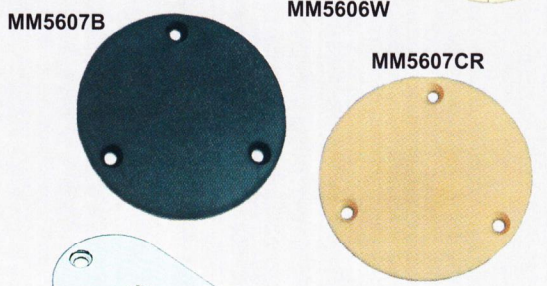
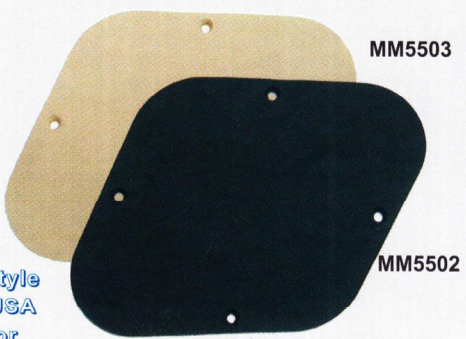

New Mighty Mite® Tall & Short Flat Metal Pickup Rings.



USA Retro-Fit

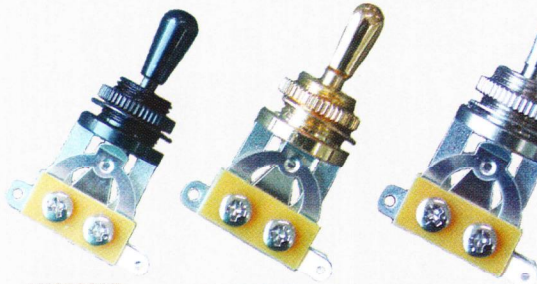

MM5020B

MM5020G

MM5020C

New! Mighty Mite® Les Paul® Style Switch



MM500

Mighty Mite® 3 Position Toggle Switch (SPDT) 500 (Black) 501 (White)

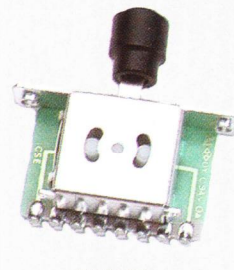

MM533

Mighty Mite® Tele® Replacement 3 Way Switch With Black Knob

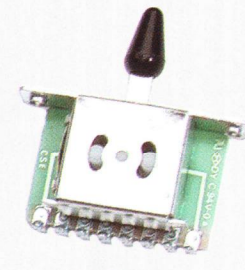

MM511

Mighty Mite® 3 Way Switch (Double Pole) 511 (Black) 512 (White)

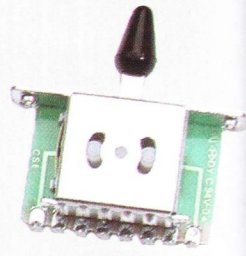

MM503

Mighty Mite® Strat® Replacement 5 Way Switch With Black Knob (Double Pole)

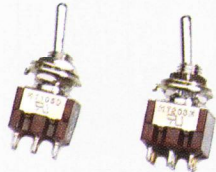

MM518

MM520

Mighty Mite® Mini Toggles 518(SPDT) (520DPDT)



MM112

Mighty Mite® 1/4" Barrel End Pin Input Jack



MM111

Mighty Mite® 1/4" Barrel Input Jack Stereo



MMJC10N  
MMJC11B  
MMJC12G

Mighty Mite® 1/4" Input Jack Available in Nickel / BIK / Gld Mono



MMJC20N  
MMJC21B  
MMJC22G

Mighty Mite® 1/4" Input Jack Available in Nickel / BIK / Gld Stereo



MM700

Mighty Mite® A250K Audio Short Shaft Dime Size



MM700L

Mighty Mite® A250K Audio Long Shaft Dime Size



MM701

Mighty Mite® B250K Linear Short Shaft Dime Size



MM701L

Mighty Mite® B250K Linear Long Shaft Dime Size



MM702

Mighty Mite® D500K Audio Short Shaft Dime Size



MM707

Mighty Mite® A500K Audio Short Shaft Dime Size



MM707L

Mighty Mite® A500K Audio Long Shaft Dime Size



MM708

Mighty Mite® B500K Linear Short Shaft Dime Size



MM708L

Mighty Mite® B500K Linear Long Shaft Dime Size

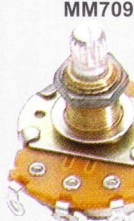

MM709

Mighty Mite® A500K Audio Control Pot Quarter Size



MM710

Mighty Mite® B500K Linear Control Pot Quarter Size



MM712

Mighty Mite® D500K Audio Control Pot Quarter Size



MM714

Mighty Mite® A250K Audio Control Pot Quarter Size



MM716

Mighty Mite® B250K Linear Control Pot Quarter Size Short Shaft

New!! Mighty Mite® Sealed Control Pots

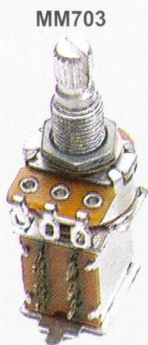

MM703

Mighty Mite® Push-Pull A250K Audio



MM704

Mighty Mite® Push-Pull A500K Audio



MM706

Mighty Mite® Push-Pull B500K Audio



MM717

Mighty Mite® A250K Audio Long Shaft Quarter Size



MM717L

Mighty Mite® B250K Linear Long Shaft Quarter Size



MM718

Mighty Mite® A500K Audio Long Shaft Quarter Size



MM718L

Mighty Mite® B500K Linear Long Shaft Quarter Size





MM916/920



MM914/918



MM917/919



MM910/912



MM922



MM908



MMKN007GC



MMKN007BG



MMKN007CC



MMKN007CG



MMNP002GAT



MMNP002CAT



MMNP002BAT



MMNS006G



MMNP002GWP



MMNP002CWP



MMNP002BWP



MMNS006C

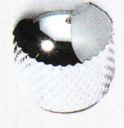

MMNS006B



MMNS001CAT



MMNS001GAT

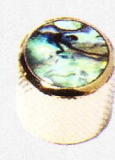

MMNS001BAT

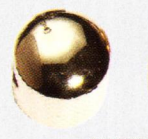

MM909G



MMNS001CWP



MMNS001GWP



MMNS001BWP



MM909C



MMNS001CBP



MMNS001GBP



MMNS001BBP



MM909B

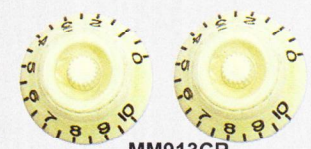

MM913CR

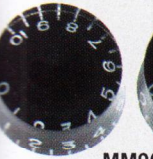
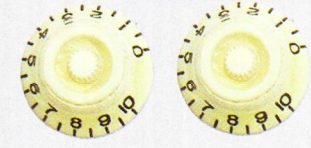

MM902



MM904



MM900



MM913BK



MM913AM

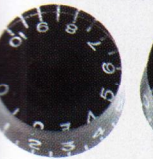





MMJ01

3X3 Tuners, Available In, Chrome-Black & Gold Set Of 6



MMJ101

3X3 Tuners, Available In, Chrome-Black & Gold Set Of 6



MMJ026

6 In-line Tuners, Available In, Chrome-Black & Gold Set Of 6



MMJ04

3X3 Tuners, Available In, Chrome-Black & Gold Set Of 6



MMJ44

3X3 Tuners, Available In, Nickel & Gold Set Of 6



MMJ807

3X3 Tuners, Available In, Chrome-Black & Gold Set Of 6



MMJ05

6 In-Line Tuners, Available In, Chrome-Black & Gold Set Of 6



MMJ805

6 In-Line Tuners, Available In, Chrome-Black & Gold Set Of 6



MMJ404H

With Winder

3X3 Tuners, Available In, Chrome-Black & Gold Set Of 6



MMJB150

Bass Tuners, 2x2 / 3x2 Black-Chrome & Gold

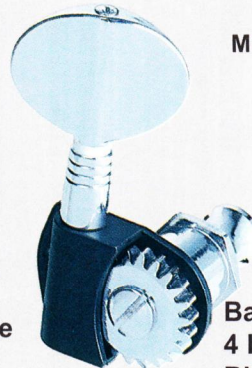

MMJB300

Bass Tuners, 4 In-Line Black-Chrome & Gold



MMJB200

Bass Tuners, 4 In-Line Black-Chrome & Gold

New!! Mighty Mite® Machine Head Buttons, Each is available packaged in sets of 6 and in chrome black or gold. Just add C-B-G at the end of the item number for the color.



MMK01



MMK03



MMK03M



MMK04



MMK04H



MMK05



MMK09



MMK09M



MMK10



MMKB1



MMKB4



MMKB5



**MMRK2**

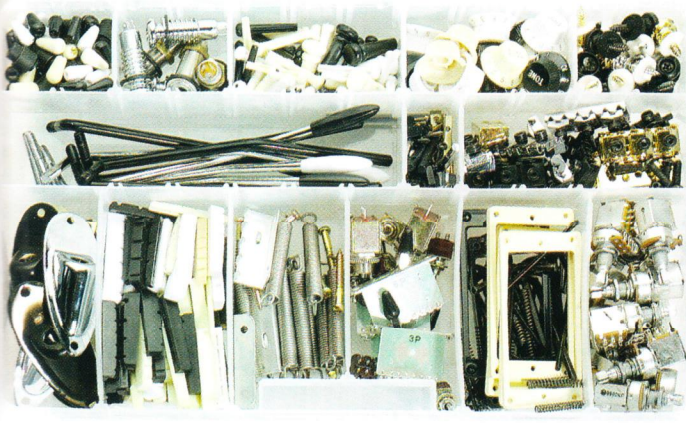

<b>Switch Knobs</b> 10-BK504 10-BK514 10-BK506 10-BK515 10-BK508 10-BK516 10-BK510 10-BK534	<b>Input Jacks</b> 3-BK111 3-BK112	<b>Bridge Pins &amp; End Pins</b> 10-BK2300B / 3-BK2300E 10-BK2302B / 3-BK2302E 10-BK2304B / 3-BK2304E	<b>Strat® Knobs</b> 2-BK914 2-BK916 2-BK917 2-BK918 2-BK919 2-BK920	<b>Strap Button</b> 4-BK5610B 4-BK5610C 4-BK5610G 4-BK5612B 4-BK5612C 4-BK5612G
<b>Tremolo Arms</b> 2-BK1302 / 4-BK1300 / 2-BK1304		<b>Retainer Bar / Tree's</b> 2-BK1506B 5-BK1508B 2-BK1506C 5-BK1508C 1-BK1506G 3-BK1508G		<b>Locking Nuts</b> 2-BKPL001C 2-BKPL002B 2-BKPL002C 2-BKPL001G 2-BKPL001B 2-BKPL002G
<b>Strat Recessed Jack Plates</b> 2-BK5600-BLK 2-BK5601-CHRM 2-BK5602-GLD 2-BK5603C 2-BK5603G 2-BK5603B	<b>Assorted Nuts</b> BK2500 / 55 Pkg  <b>Acoustic Saddles</b> 15 (Pkg)	<b>Hooks Springs Screws</b> 3-BK4200 15-BK4300 10-BK4400	<b>Switches</b> 2-BK500 2-BK503 2-BK511 2-BK518 2-BK520	<b>Humbucker Mounting Rings</b> 2-BK300B-S 2-BK300B-T 2-BK300CR-S 2-BK300CR-T
				<b>Pots</b> 2-BK700 2-BK702 2-BK703 2-BK704 2-BK706 2-BK710 2-BK712 2-BK714 30-Wash/Nut

Item	Description	Qty/RK1	Qty/RK2	Item	Description	Qty/RK1	Qty/RK2
BK111	1/4" Barrel Style Input Jack	7	3	BKPL001C	Locking Nut / Complete Set w/ Wrench 1-5/8" (Chrome)	5	2
BK112	1/4" Barrel Style End Pin Input Jack	7	3	BKPL002C	Locking Nut / Complete Set w/ Wrench 1-11/16" (Chrome)	5	2
BK300B-S	Short Plastic Humbucker Pickup Ring (Black)	5	2	BKPL001B	Locking Nut / Complete Set w/ Wrench 1-5/8" (Black)	5	2
BK300B-T	Tall Plastic Humbucker Pickup Ring (Black)	5	2	BKPL002B	Locking Nut / Complete Set w/ Wrench 1-11/16" (Black)	5	2
BK300CR-S	Short Plastic Humbucker Pickup Ring (Cream)	5	2	BKPL001G	Locking Nut / Complete Set w/ Wrench 1-5/8" (Gold)	5	2
BK300CR-T	Tall Plastic Humbucker Pickup Ring (Cream)	5	2	BKPL002G	Locking Nut / Complete Set w/ Wrench 1-11/16" (Gold)	5	2
BK500	3 Position Toggle Switch (Black Knob)	5	2	BK1506C	String Retainer Bar (Chrome)	5	2
BK503	5 Way Switch (Black Knob)	5	2	BK1506B	String Retainer Bar (Black)	5	2
BK504	Knobs For 3 & 5 Way Switch (Black)	22	10	BK1506G	String Retainer Bar (Gold)	3	1
BK506	Knobs For 3 & 5 Way Switch (Cream)	22	10	BK1508C	Roller String Tree (Chrome)	11	5
BK508	Knobs For 3 Position Toggle Switch (Black)	22	10	BK1508B	Roller String Tree (Black)	11	5
BK510	Knobs For 3 Position Toggle Switch (Cream)	22	10	BK1508G	Roller String Tree (Gold)	5	3
BK511	3 Way Switch (Black Knob)	5	2	BK2300B	Bridge Pin / White w/ Black Dot	22	10
BK514	Knobs For 5 Way Switch (Black)	22	10	BK2300E	End Pin / White w/ Black Dot	7	3
BK515	Knobs For 5 Way Switch (Cream)	22	10	BK2302B	Bridge Pin / Black w/ White Dot	22	10
BK516	Knobs For 5 Way Switch (White)	22	10	BK2302E	End Pin / Black w/ White Dot	7	3
BK518	Mini Toggle Switch / 3 Single Terminal System	5	2	BK2304B	Bridge Pin / Cream w/ Black Dot	22	10
BK520	Mini Toggle Switch / 3 Dual Terminal System	5	2	BK2304E	End Pin / Cream w/ Black Dot	7	3
BK534	Knobs For 3 Way Switch (Black)	22	10	BK2400	Acoustic Guitar Saddle (Cream)	33	15
BK700	Control Pot / A250K Audio Short Shaft Dime Size	5	2	BK2500	Assorted String Nut Package / 55 Pcs	110 / PCS	55 / PCS
BK702	Control Pot / D500K Audio Short Shaft Dime Size	5	2	BK4200	Tremolo Spring Claw Hook	7	3
BK703	Control Pot / A250K Audio Push Pull	5	2	BK4300	Tremolo Springs	33	15
BK704	Control Pot / A500K Audio Push Pull	5	2	BK4400	Tremolo Spring Claw Hook Screw	22	10
BK706	Control Pot / B500K Linear Push Pull	5	2	BK5600	Strat® Replacement Recessed Jack Plate (Black)	5	2
BK710	Control Pot / B500K Linear Quarter Size	5	2	BK5601	Strat® Replacement Recessed Jack Plate (Chrome)	5	2
BK712	Control Pot / D500K Audio Quarter Size	5	2	BK5602	Strat® Replacement Recessed Jack Plate (Gold)	5	2
BK714	Control Pot / A250K Audio Quarter Size	5	2	BK5603B	Les Paul® Replacement Jack Plate (Black)	5	2
BK914	Control Knob / Strat® Replacement / Volume (Black)	5	2	BK5603C	Les Paul® Replacement Jack Plate (Chrome)	5	2
BK916	Control Knob / Strat® Replacement / Volume (White)	5	2	BK5603G	Les Paul® Replacement Jack Plate (Gold)	5	2
BK917	Control Knob / Strat® Replacement / Volume (Cream)	5	2	BK5610B	Strap Button / Traditional Style (Black)	9	4
BK918	Control Knob / Strat® Replacement / Tone (Black)	9	4	BK5610C	Strap Button / Traditional Style (Chrome)	9	4
BK919	Control Knob / Strat® Replacement / Tone (Cream)	9	4	BK5610G	Strap Button / Traditional Style (Gold)	9	4
BK920	Control Knob / Strat® Replacement / Tone (White)	9	4	BK5612B	Strap Button / Contemporary Style (Black)	9	4
BK1300C	Tremolo Arm / Floyd Rose® Replacement (Chrome)	9	4	BK5612C	Strap Button / Contemporary Style (Chrome)	9	4
BK1302	Tremolo Arm / Strat® Replacement / (White Knob)	5	2	BK5612G	Strap Button / Contemporary Style (Gold)	9	4
BK1304	Tremolo Arm / Strat® Replacement / (Black Knob)	5	2				

**NOTE:** RK1, Control Pots Come With 60 pcs Of Extra Washers & Nuts  
RK2, Control Pots Come With 30 pcs Of Extra Washers & Nuts

**MM2500 String Nut Package**  
5- Acoustic Style 1-11/16" (White)  
5- Les Paul® Style 1-11/16" (Cream)  
6- Acoustic Style 1-11/16" (Cream)  
5- Les Paul® Style 1-11/16" (White)  
4- Classical Style 2" (White)  
5- Acoustic Style 1-11/16" (Black)  
6- Les Paul® Style 1-11/16" (Black)

4- 5 String Bass Style 1-3/4" (Black)  
5- 4 String Bass Style 1-11/16" (Black)  
5- 4 String Bass Thin Style 43X3T (Black)  
5- Electric Guitar Style 43X3T (Cream)

**NOTE: RK1 comes with 2 MM2500 Packages**

**MMSK1**



<b>Neck Plate Screws</b> 50-BK7100C 50-BK7100B 25-BK7100G	<b>Humbucker Pickup Screws</b> 100-BK7700B 100-BK7700C 25-BK7700G	<b>Strap Button Screws</b> 50-BK7400B	<b>Strap Button Screws</b> 50-BK7400C
<b>Pickguard Screws</b> 100-BK7000B 100-BK7000C 100-BK7000G	<b>Machine Head Screws</b> 100-BK730B 100-BK730C	<b>Guitar Pickup Screws</b> 100-BK7500B	<b>Strap Button Screws</b> 25-BK7400G
	<b>Humbucker Ring Screws</b> 100-BK7200B-SHRT 100-BK7200B-TALL 100-BK7200C-SHRT 100-BK7200C-TALL	<b>Humbucker Ring Springs</b> 50-BK7800	<b>Bass Guitar Pickup Screws</b> 100-BK7600C 100-BK7600B

Strat®, P-Bass®, J-Bass®, Tele® are trademarks of Fender Musical Instruments Corp. Mighty Mite® is not affiliated with Fender Musical Instruments Corp. Les Paul® is a trademark of Gibson Musical Instruments Co. which is not affiliated, Floyd Rose® is not affiliated, Wilkinson® is not affiliated with Mighty Mite®



MM100



Mighty Mite® 3 Band EQ / Pre-Amp

MM116



Mighty Mite® 4 Band Active EQ w/ Treble, Bass, Mid, 1Khz - 2Khz Control And Battery Light

MM104



Mighty Mite® Transducer Pickup, w/ Tone Controls

MM102



Mighty Mite® 3 Band EQ / Pre-Amp w/ Slim Jim® Bridge Mount Pickup

MM103



Mighty Mite® 4 Band Active EQ w/ Treble, Bass, Mid, 1Khz - 2Khz Control And Battery Light w/ Slim Jim® Under The Saddle Acoustic Guitar Pickup

MM110

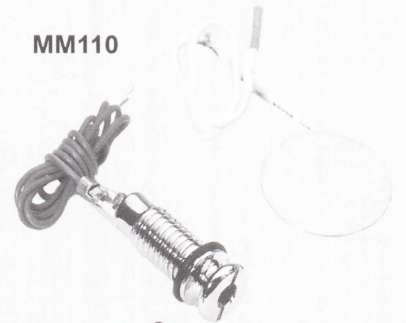

Mighty Mite® Transducer Pickup, Internal Mounting w/ End Pin Jack

MM505



Mighty Mite® 3 Band Active EQ, Plus Volume Control

MM108

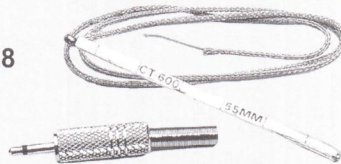

Slim Jim® Under The Saddle Acoustic Bass Guitar Pickup

MM555



Mighty Mite® 4 Band Active EQ, Plus Volume Control

MM106

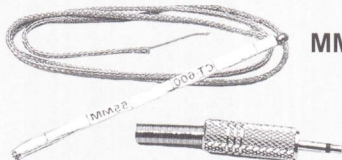

Slim Jim® Under The Saddle Acoustic Guitar Pickup

MM7580



Mighty Mite® 3 Band Active EQ, Plus Volume Control, w/ Slim Jim® Bridge Mount Pickup

MM7585

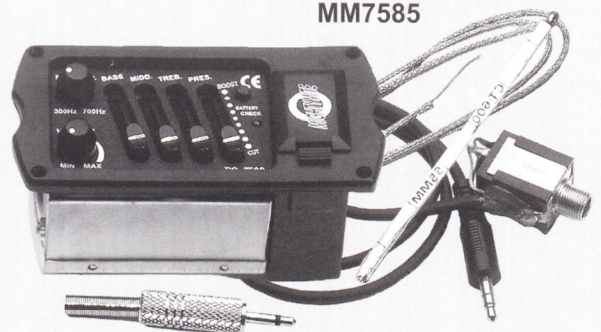

Mighty Mite® 3 Band Active EQ, Plus Volume Control, w/ Slim Jim® Bridge Mount Pickup



MM5904BK

MM5401

MM5400

MM5904W

MM5904R

MM5904BL

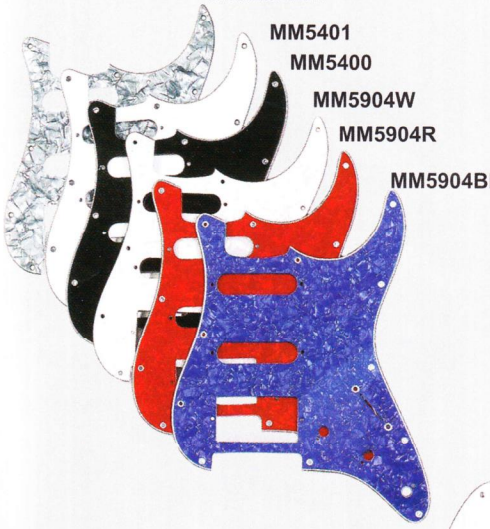

MM5304

MM5305

MM5306



MM5301

MM5302

MM5300

MM5303

MM5903BL

MM5903W

MM5903R

MM5903BK

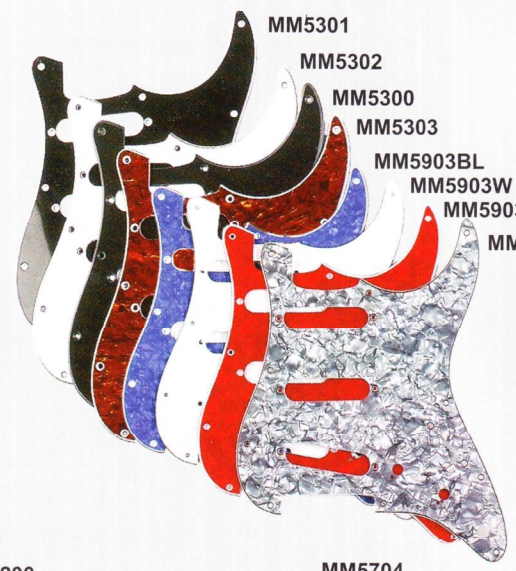

MM5905W

MM5905BK

MM5202

MM5201

MM5200



MM5700

MM5701

MM5702

MM5906W

MM5906BK

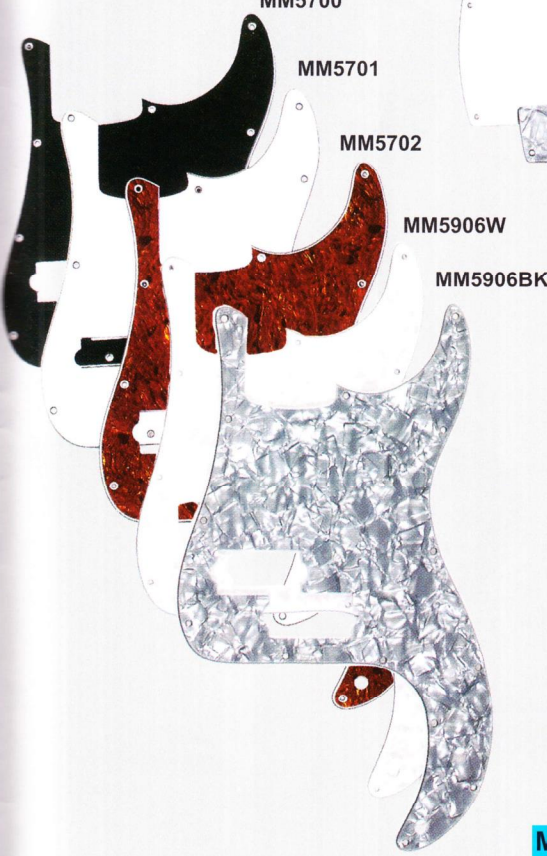

MM5704

MM5703

MM5907W

MM5907BK



MM1902

MM1900



MM5800

MM5801

MM5803

MM5802

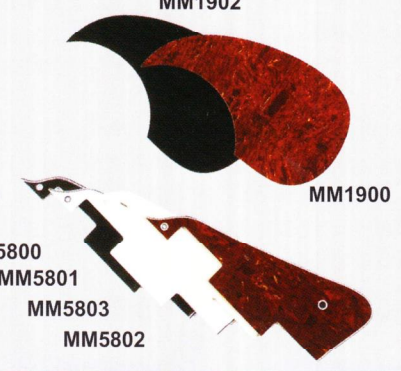

NEW!! MIGHTY RAIL® PICKUPS

USA RETRO-FIT BLACK PEARL GUARD

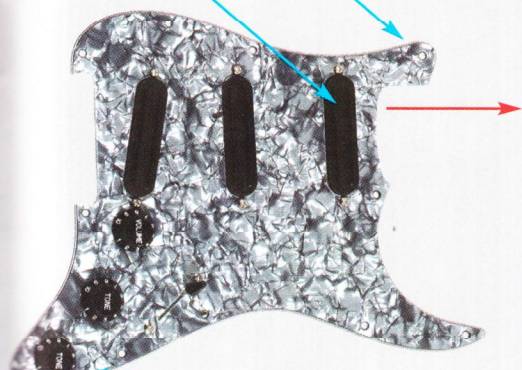

500K POTS

**Mighty Mite® Pre-Wired Pickguard Assemblies**

OUR LEGENDARY PICKUPS ARE BACK FOR THE ATTACK!! IN LOADED GUARDS, EVERYTHING YOU NEED IS THERE AND READY TO DROP INTO YOUR HOT-ROD. 2 GROUNDS, A HOT WIRE AND SLAM!!!

- MM400W - SSS / W/B/W W/ MIGHTY MITE® MMPSS SINGLE COILS (KOREAN) / STRAT®
- MM400B - SSS / B/W/B W/ MIGHTY MITE® MMPSS SINGLE COILS (KOREAN) / STRAT®
- MM400TS - SSS TORTOISE W/ MIGHTY MITE® MMPSS SINGLE COILS (KOREAN) / STRAT®
- MM405W - HSS / W/B/W W/ MIGHTY MITE® MMHG & MMPSS PICKUPS (KOREAN) / STRAT®
- MM405B - HSS / B/W/B W/ MIGHTY MITE® MMHG & MMPSS PICKUPS (KOREAN) / STRAT®
- MM405TS - HSS TORTOISE W/ MIGHTY MITE® MMHG & MMPSS PICKUPS (KOREAN) / STRAT®
- MM402B - SSS / B/W/B W/ NEW MIGHTY RAILS® - USA RETRO-FIT / STRAT®
- MM402BP - SSS / BLACK PEARL W/ NEW MIGHTY RAILS® - USA RETRO-FIT / STRAT®
- MM402W - SSS / W/B/W W/ NEW MIGHTY RAILS® - USA RETRO-FIT / STRAT®
- MM402WP - SSS / WHITE PEARL W/ NEW MIGHTY RAILS® - USA RETRO-FIT / STRAT®
- MM403B - HSS / B/W/B W/ MOTHERBUCKER® & MIGHTY RAILS® - USA RETRO-FIT / STRAT®
- MM403BP - HSS / BLACK PEARL W/ MOTHERBUCKER® & MIGHTY RAILS® - USA RETRO-FIT / STRAT®
- MM403W - HSS / W/B/W W/ MOTHERBUCKER® & MIGHTY RAILS® - USA RETRO-FIT / STRAT®
- MM403WP - HSS / WHITE PEARL W/ MOTHERBUCKER® & MIGHTY RAILS® - USA RETRO-FIT / STRAT®
- MM404B - HH / B/W/B W/ MOTHERBUCKERS® & - USA RETRO-FIT / STRAT®
- MM404BP - HH / BLACK PEARL W/ MOTHERBUCKER'S® & - USA RETRO-FIT / STRAT®
- MM404W - HH / W/B/W W/ MOTHERBUCKER'S® & - USA RETRO-FIT / STRAT®
- MM404WP - HH / WHITE PEARL W/ MOTHERBUCKER'S® & - USA RETRO-FIT / STRAT®





Mighty Mite® Has developed an all new USA Retro-Fit Parts Line. Check out our new USA Retro-Fit Pickguards, Fits all USA & Mexican Strat's® Tele's® P-Bass® & J-Bass® Guitars. They line right up.

Mighty Mite's® All New Pre-Loaded Hot-Rod USA Retro-Fit Pickguards Loaded with our new Motherbucker® & Mighty Rail® Pickups. We use the finest Alnico 5 & Ferrite Magnets and the same gauge wire & Components as our USA Competitors. The tone of our pickups will blow your mind!!

