

CATALOG # 3809

WE'VE GOT ALL THE RIGHT PARTS!



WE'VE GOT ALL THE RIGHT PARTS!



Photos By Jeff Tylel
Model: Bunny Hartman

UPGRADE TO **MIGHTY MITE** PICK-UPS & PARTS AT YOUR DEALER

3451 West Commercial Avenue • Northbrook, IL 60062 USA • Phone: 847-498-MITE • Fax: 847-498-5370
 E-mail: mitesales@mightymite.com • Web: www.MIGHTYMITE.com

Since the 1970's, Mighty Mite® has supplied quality guitar parts to some of the best luthiers in the Industry. Our pride and customer service are un-matched and Mighty Mite® Bodies & Necks are made from the finest American Ash and Canadian Maple.

We offer P bass®, J Bass®, Strat® & Tele® replacement bodies in a wide variety of colors and styles. From Hard Tail Strats® to Rear Routed 1 Hum Charvels® We have what you're looking for to build that custom axe. All Mighty Mite® Bodies are cut from American Swamp Ash and the Flame & Quilt Tops are a real maple veneer. You will be blown away by the warmth, tone and finish. See Chart below:

A= Ash, Sanded & Sealed
 AF= Ash, Finished
 AFF= Ash, Finished, Flame Top
 AFQ= Ash, Finished, Quilt Top
 AFFR= Finished, Flame Top, Rear Route
 AFQR= Finished, Quilt Top, Rear Route
 H= 1 Hum Charvel Style, AFFRH
 NT= Hard Tail, 270NTAFQ-CRS
 CRS= Cherry Sunburst
 2TS= Two Tone Tobacco Sunburst
 3TS= Three Tone Tobacco Sunburst
 NAT= Natural
 BK= Black
 BLB= Blue Burst
 STBL= See Through Blue
 STBK= See Through Black
 SFGR= Seafoam Green
 STR= See Through Red
 WHT= Alpine White
 AWHT= Antique White
 RSPRKL= Red Sparkle
 BSPRKL= Blue Sparkle
 SSPRKL= Silver Sparkle
 GSPRKL= Gold Sparkle



MM2900 MM2902 MM2912 MM2910 MM2902V MM2903 MM2900V MM2902L MM2900L MM2905 MM2904 MM2905V MM2924 MM2916



MM2914

MM2920 MM2906 MM2907 MM2919 MM2908 MM2909



Since the 1970's, Mighty Mite® has manufactured custom parts for the dreamer, You know!! The guy that can't wait to hot-rod his axe. Mighty Mite® has teamed up with Jetfrets® and we will now be offering American Made Mighty Mite® Necks with Jetfrets®. You will be amazed by the Tone & Sustain

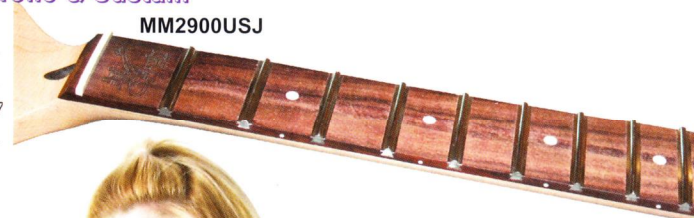

MM2900USJ



MM2934

MM2935 = Maple



MM2928



MM2929

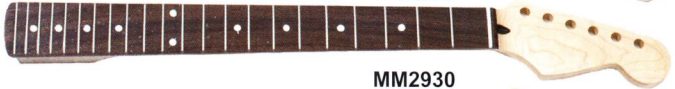

MM2930



MM2925



MM2926

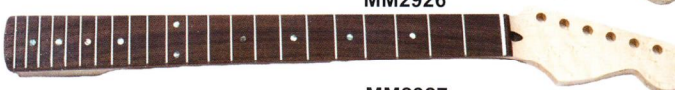

MM2927

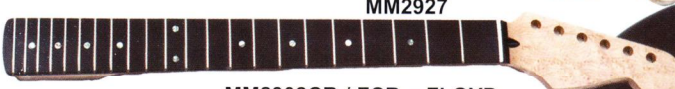

MM2902CR / FCR = FLOYD



MM2900CR / FCR = FLOYD

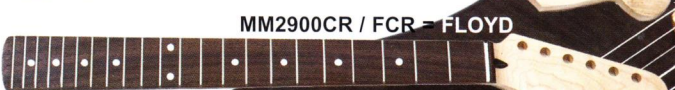

MM2910CR / FCR = FLOYD



MM2922



MM2902FCR

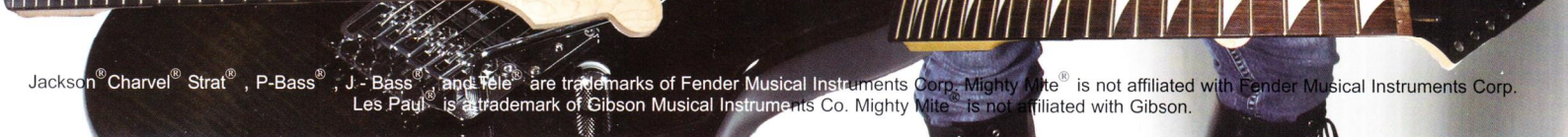

MMPSS-F/BK

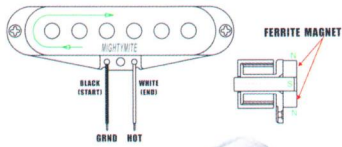

RESISTANCE : 5.2Kohm
INDUCTANCE : 3.8H

Single Coil Strat Replacement, Ultra Quiet with AWESOME Tone. Neck Position

MMRSS-FM/BK

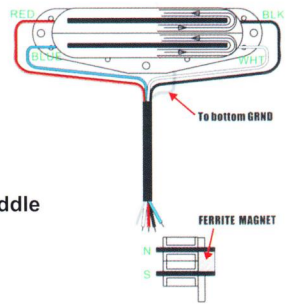

RESISTANCE : 10.5Kohm
INDUCTANCE : 4.6H

New!! Mighty Mite® "Mighty Rail®" Pickup / Neck - Middle Bare+White is GRND, Red+Blue to Coil tap, Black is Hot output.

MMPSS-F/WH



RESISTANCE : 5.2Kohm
INDUCTANCE : 3.8H

Single Coil Strat Replacement, Ultra Quiet with AWESOME Tone. Neck Position

MMRSS-FM/WH

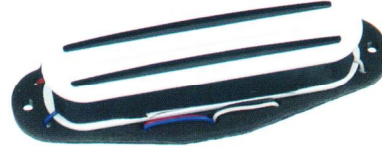

RESISTANCE : 10.5Kohm
INDUCTANCE : 4.6H

New!! Mighty Mite® "Mighty Rail®" Pickup / Neck - Middle Bare+White is GRND, Red+Blue to Coil tap, Black is Hot output.

MMPSS-M/BK



RESISTANCE : 5.2Kohm
INDUCTANCE : 3.8H

Single Coil Strat Replacement, Ultra Quiet with AWESOME Tone. Middle Position

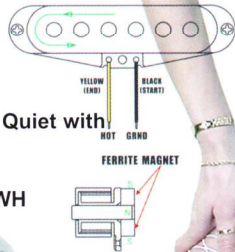

MMRSS-FM/BK

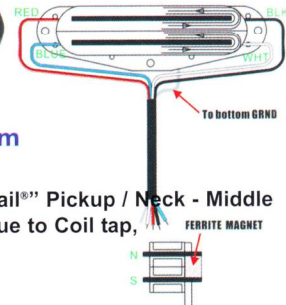

RESISTANCE : 10.5Kohm
INDUCTANCE : 4.6H

New!! Mighty Mite® "Mighty Rail®" Pickup / Neck - Middle Bare+White is GRND, Red+Blue to Coil tap, Black is Hot output.

MMPSS-M/WH



RESISTANCE : 5.2Kohm
INDUCTANCE : 3.8H

Single Coil Strat Replacement, Ultra Quiet with AWESOME Tone. Middle Position

MMRSS-FM/WH



RESISTANCE : 10.5Kohm
INDUCTANCE : 4.6H

New!! Mighty Mite® "Mighty Rail®" Pickup / Neck - Middle Bare+White is GRND, Red+Blue to Coil tap, Black is Hot output.

MMPSS-R/BK



RESISTANCE : 5.2Kohm
INDUCTANCE : 3.8H

Single Coil Strat Replacement, Ultra Quiet with AWESOME Tone. Bridge Position

RESISTANCE : 14.3Kohm
INDUCTANCE : 9.8H

New!! Mighty Mite® "Mighty Rail®" Pickup / Neck - Middle Bare+White is GRND, Red+Blue to Coil tap, Black is Hot output.

MMRSS-R/BK

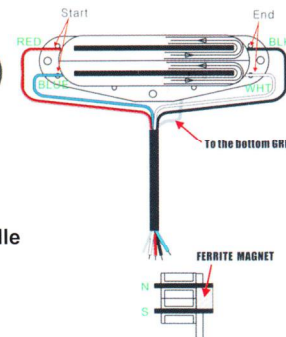

MMPSS-R/WH



RESISTANCE : 5.2Kohm
INDUCTANCE : 3.8H

Single Coil Strat Replacement, Ultra Quiet with AWESOME Tone. Bridge Position

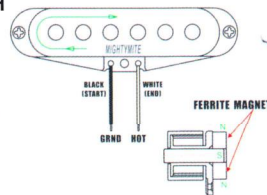

MMRSS-R/WH



RESISTANCE : 14.3Kohm
INDUCTANCE : 9.8H

New!! Mighty Mite® "Mighty Rail®" Pickup / Neck - Middle Bare+White is GRND, Red+Blue to Coil tap, Black is Hot output.

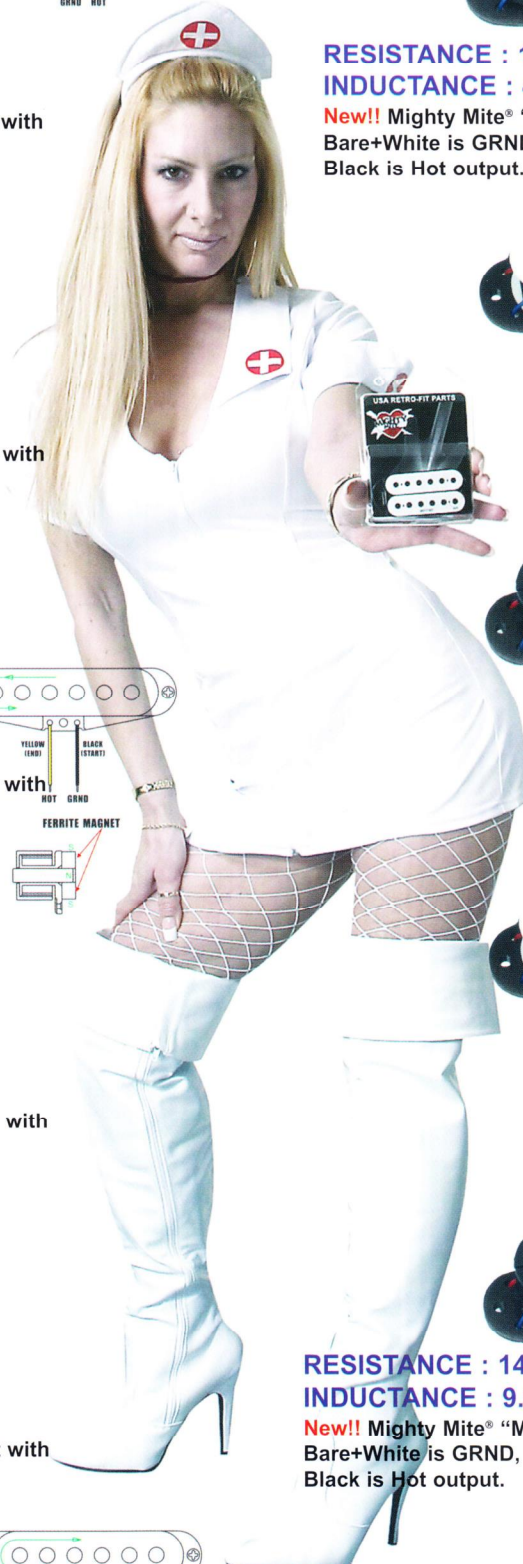

Photo By Jeff Tytel
Model, Bunny Hartman



MMVPSS-F/BK

RESISTANCE : 5.2Kohm
INDUCTANCE : 2.05H

Vintage Single Coil Strat® Replacement, Ultra Quiet w/ Alnico 5 Magnet AWESOMEVintage Tone. Neck Position

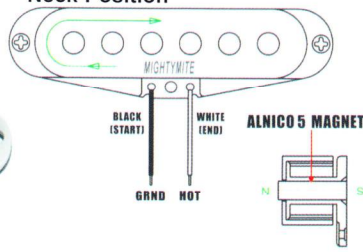

MMVPSS-F/WH



MMVPSS-M/BK

RESISTANCE : 5.2Kohm
INDUCTANCE : 2.05H

Vintage Single Coil Strat® Replacement, Ultra Quiet w/ Alnico 5 Magnet AWESOMEVintage Tone. Middle Position, Reverse Wound

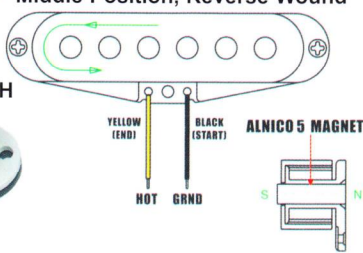

MMVPSS-M/WH



MMVPSS-R/BK

RESISTANCE : 5.2Kohm
INDUCTANCE : 2.05H

Vintage Single Coil Strat® Replacement, Ultra Quiet w/ Alnico 5 Magnet AWESOMEVintage Tone. Bridge Position

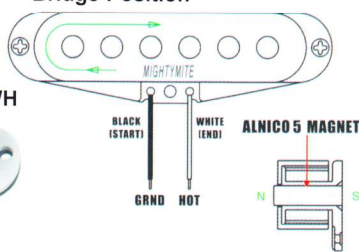

MMVPSS-R/WH

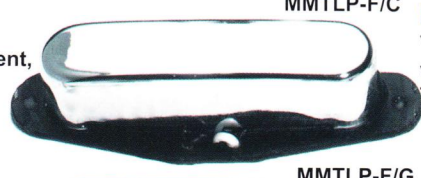

MMTLP-F/C

RESISTANCE : 6.8Kohm
INDUCTANCE : 2.08H

Vintage Tele® Replacement, Ultra Quiet w/ Alnico 5 Magnet AWESOMEVintage Tone. Neck Position

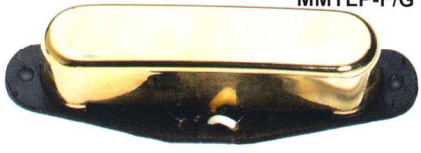
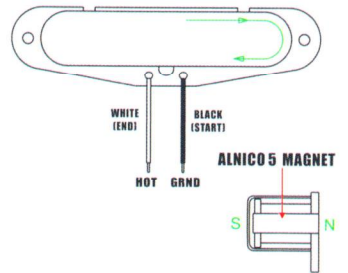

MMTLP-F/G

RESISTANCE : 7.5Kohm
INDUCTANCE : 2.85H

Vintage Tele® Replacement, Ultra Quiet w/ Alnico 5 Magnet AWESOMEVintage Tone. Bridge Position

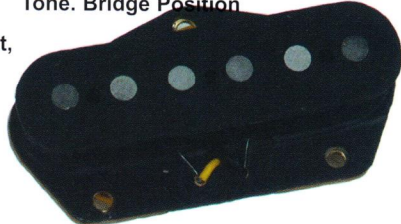
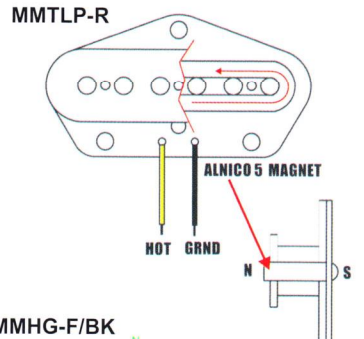

MMTLP-R



MMHG-F/BK

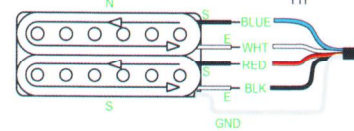

RESISTANCE : 8.2Kohm
INDUCTANCE : 4.9H

Mighty Mite® HG Series Humbucker Neck & Bridge Position Bare+Black is GRND, Red+Blue to Coil tap, white is Hot output. Reverse Wound

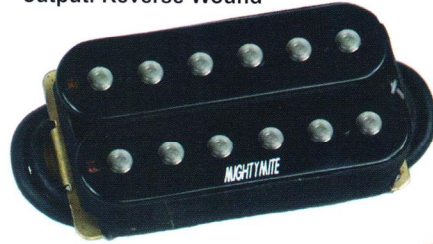

MMHG-R/BK

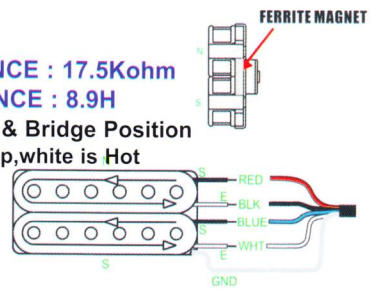

MMP90-F/CR



MMP90-F/BK

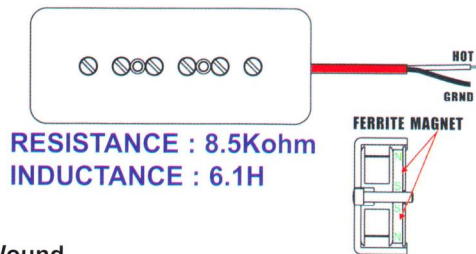

RESISTANCE : 8.5Kohm
INDUCTANCE : 6.1H

Mighty Mite® P90 Pickups, Neck & Bridge Position Black. True P90 Tone Reverse Wound

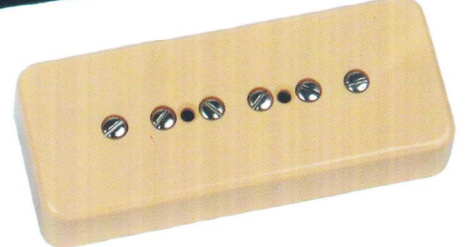

Mighty Mite® P90 Pickups, Neck & Bridge Position Cream. True P90 Tone Reverse Wound

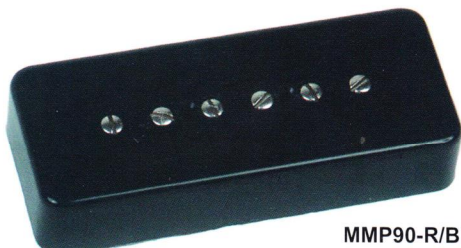

MMP90-R/BK

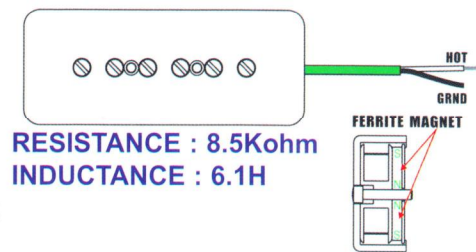

RESISTANCE : 8.5Kohm
INDUCTANCE : 6.1H

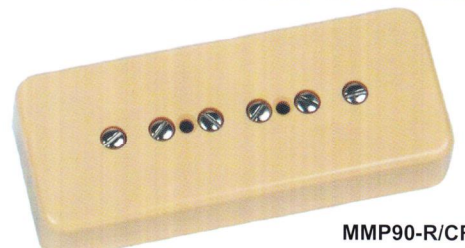

MMP90-R/CR

RESISTANCE : 11.7Kohm
INDUCTANCE : 5.5H

MMHB-F/BK

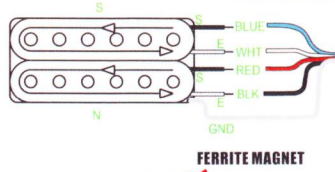

FERRITE MAGNET

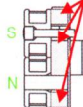

New!!Mighty Mite® "BlueBucker®" Neck & Bridge Position Pickups - Bare+White is GRND, Red+Blue to Coil tap, Black is Hot output.

RESISTANCE : 18.5Kohm
INDUCTANCE : 11.7H



MMHB-R/BK

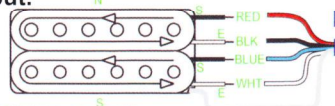

FERRITE MAGNET



RESISTANCE : 17.8Kohm
INDUCTANCE : 9.7H

MMHD-F/BK

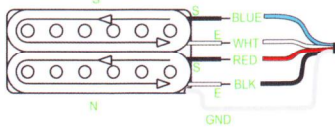

ALNICO 5 MAGNET



New!!Mighty Mite® "Motherbucker®" Neck & Bridge Position Pickups - Bare+White is GRND, Red+Blue to Coil tap, Black is Hot output.

RESISTANCE : 22Kohm
INDUCTANCE : 14H



MMHD-R/BK

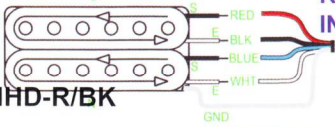

ALNICO 5 MAGNET

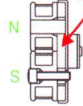

RESISTANCE : 17.8Kohm
INDUCTANCE : 9.7H

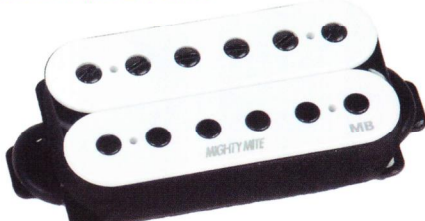

MMHD-F/WH

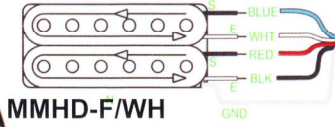

ALNICO 5 MAGNET

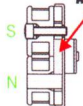

New!!Mighty Mite® "Motherbucker®" Neck & Bridge Position Pickups - Bare+White is GRND, Red+Blue to Coil tap, Black is Hot output.

RESISTANCE : 22Kohm
INDUCTANCE : 14H

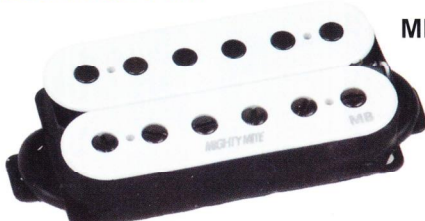

MMHD-R/WH

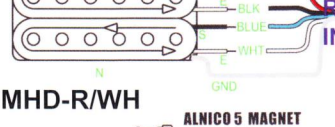

ALNICO 5 MAGNET

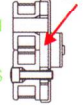

RESISTANCE : 17.8Kohm
INDUCTANCE : 9.7H

MMHD-F/ZB

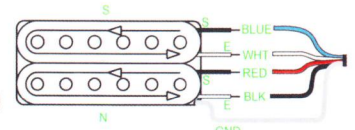

ALNICO 5 MAGNET



New!!Mighty Mite® "Motherbucker®" Neck & Bridge Position Pickups - Bare+White is GRND, Red+Blue to Coil tap, Black is Hot output.

RESISTANCE : 22Kohm
INDUCTANCE : 14H

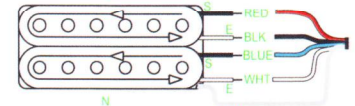

ALNICO 5 MAGNET



RESISTANCE : 8.2Kohm
INDUCTANCE : 4.4H

MMHA-F/C

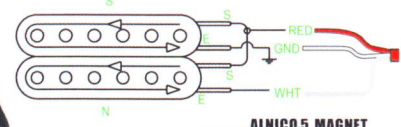

ALNICO 5 MAGNET



New!! Mighty Mite® "Vintage Bucker®" Neck & Bridge Position Pickups - White is Hot output, Red is coil tap function, Bare is GRND.

RESISTANCE : 8.2Kohm
INDUCTANCE : 4.4H



MMHA-R/C

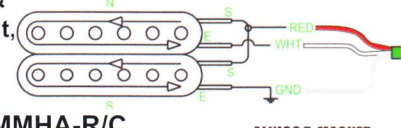

ALNICO 5 MAGNET

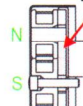

RESISTANCE : 8.2Kohm
INDUCTANCE : 4.4H

MMHA-F/G

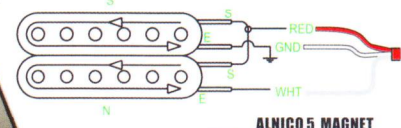

ALNICO 5 MAGNET



New!! Mighty Mite® "Vintage Bucker®" Neck & Bridge Position Pickups - White is Hot output, Red is coil tap function, Bare is GRND.

RESISTANCE : 8.2Kohm
INDUCTANCE : 4.4H

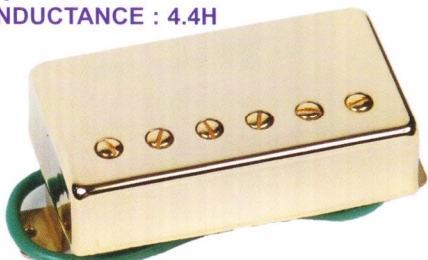

MMHA-R/G

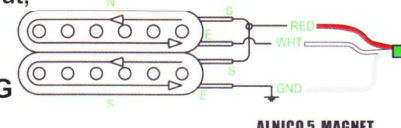

ALNICO 5 MAGNET



PICKUPS / CONT

RESISTANCE : 7Kohm
INDUCTANCE : 2.6H

MMJB-F

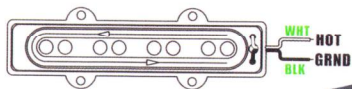

ALNICO 5 MAGNET



MMPB-4

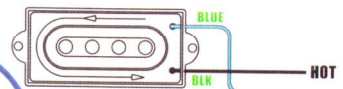
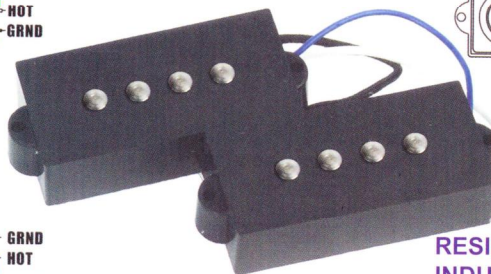

RESISTANCE : 11Kohm
INDUCTANCE : 9.1H



RESISTANCE : 7Kohm
INDUCTANCE : 2.6H

MMJB-R

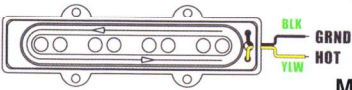

ALNICO 5 MAGNET



Mighty Mite® "PB" Pickup
WHITE WIRE IS HOT OUTPUT, AND CONNECT BLACK WIRE TO GRND

RESISTANCE : 6.25Kohm
INDUCTANCE : 4.5H

MMFR-4



TOP VIEW

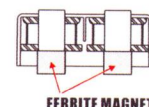

FERRITE MAGNET

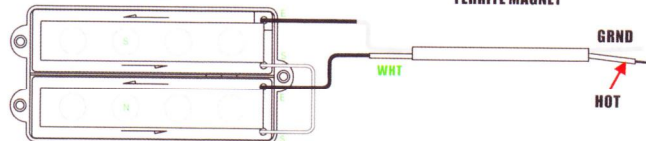

New!! Mighty Mite® "JB" Neck & Bridge Position Pickups

MMSP4-F/BK - MMSP4-R/BK

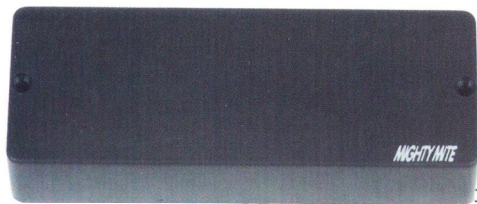

FERRITE MAGNET

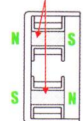

HOT OUTPUT

GRND

MMSP5-F/BK - MMSP5-R/BK

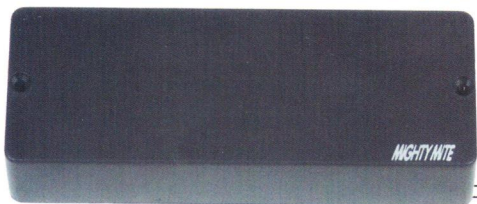

FERRITE MAGNET

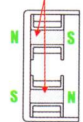

HOT OUTPUT

GRND

Mighty Mite® Passive & Active Bass Soap Bar Pickups for 4-5 & 6 String Basses.

The MM114 Is Recommended with our Active Pickups

MM114

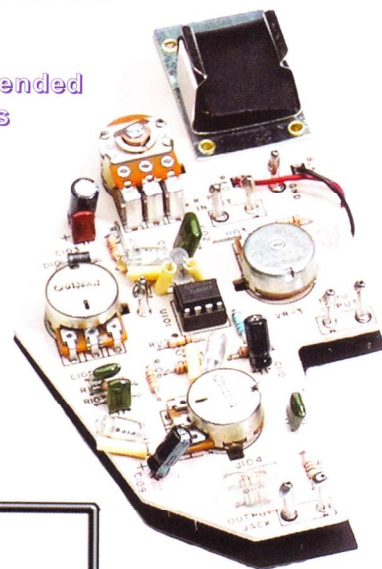

MMSA4-F/BK - MMSA4-R/BK

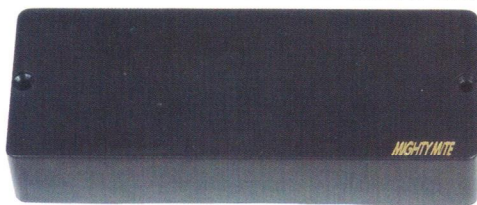

FERRITE MAGNET

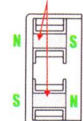

HOT OUTPUT

GRND

MMSA5-F/BK - MMSA5-R/BK

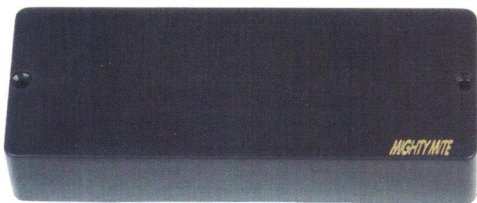

FERRITE MAGNET

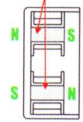

HOT OUTPUT

GRND

MMSA6-F/BK - MMSA6-R/BK



FERRITE MAGNET

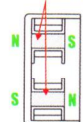

HOT OUTPUT

GRND

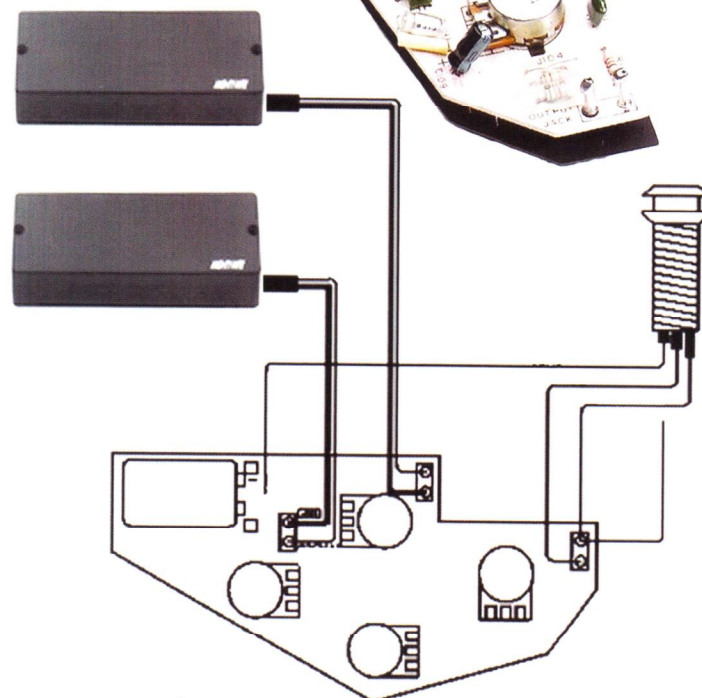

MM1100

MM1100G = Gold

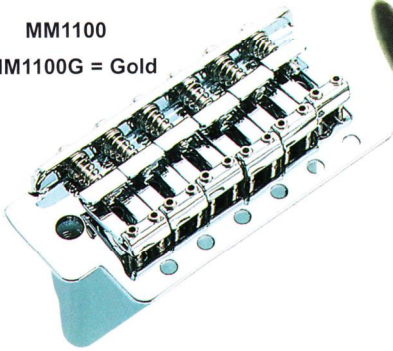

MM1112

MM1114 = Black

MM1116 = Gold



NEW!!
BRASS IS BACK!!!

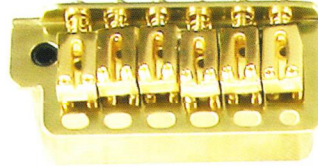

MM11133BR
USA Retro-Fit



Check out the all new
Mighty Mite® bridge line
featuring our new USA-
Retro fit Strat® & Tele® Style
Bridges. Awesome Quality
for that Hot-Rod
Project you have
been waiting to start.

MM1131C

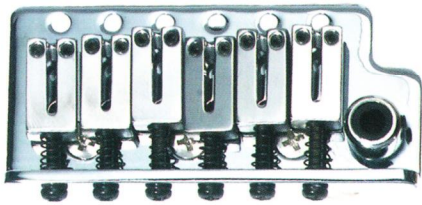

MM1131B

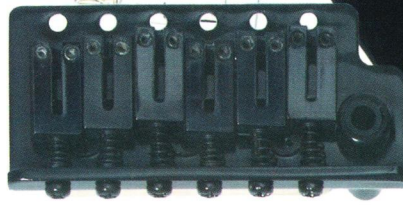

MM1131G

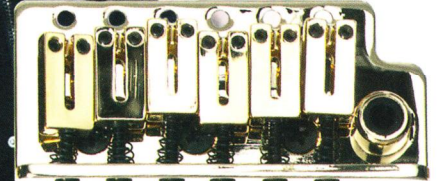

MM1132C

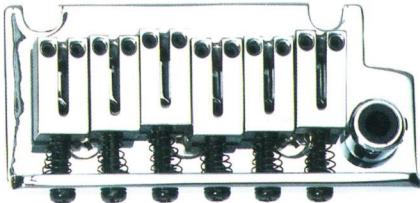

MM1132B



MM1132G

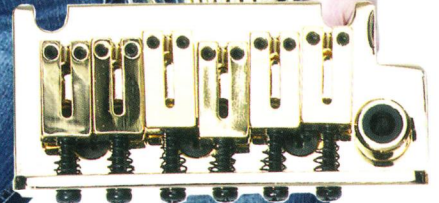

USA Retro-Fit

MM1134C

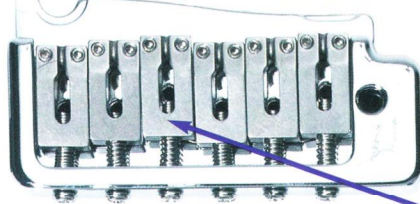

USA Retro-Fit

MM1134B

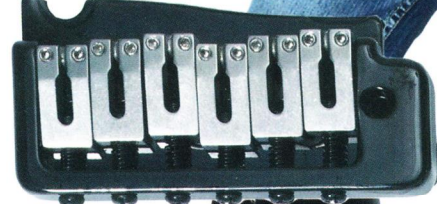

USA Retro-Fit

MM1134G

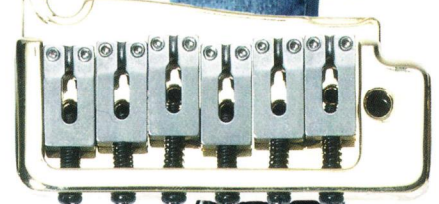

USA Retro-Fit

MM1133C

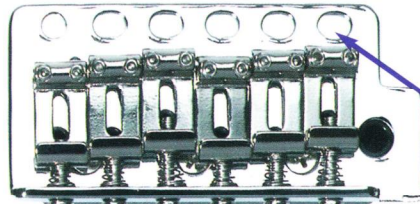

USA Retro-Fit

MM1133B

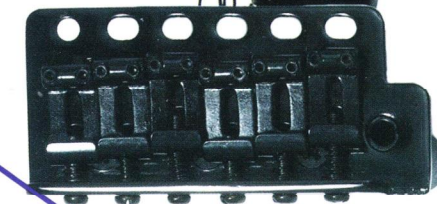

USA Retro-Fit

MM1133G

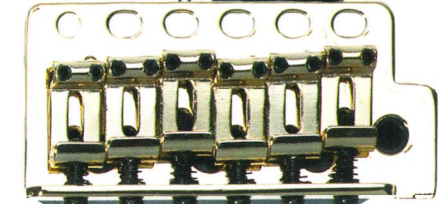

The MM1133 Series are USA Retro-Fit / Notice the Oval Shape Holes for perfect line-up and smoother action

Strat®, P-Bass®, J - Bass®, and Tele® & Charvel® are trademarks of Fender Musical Instruments Corp. Mighty Mite® is not affiliated with Fender Musical Instruments Corp.

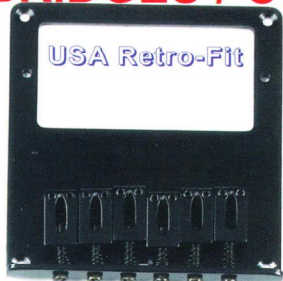

MMBT004B



MMBT004G

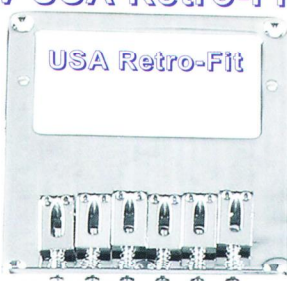

MMBT004C

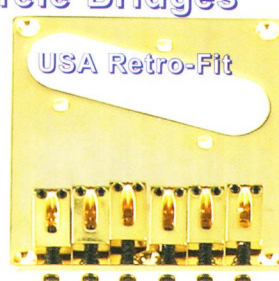

MMBT001G



MMBT001B



MM1135G

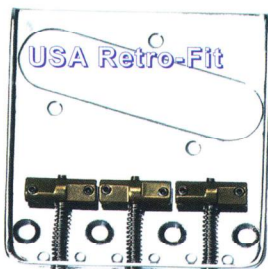

MM1135C



MM1135B

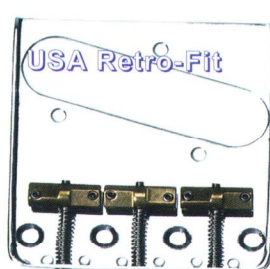

MM1135N

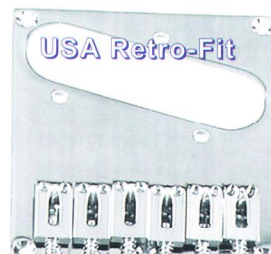

MMBT001C

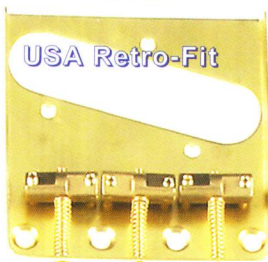

MM1135BR

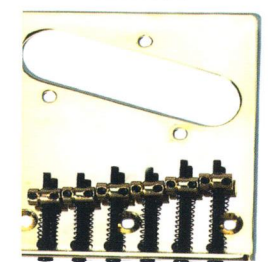

MM2112G

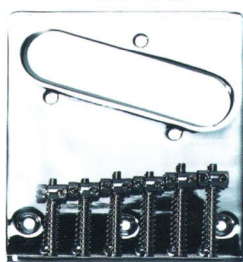

MM2112

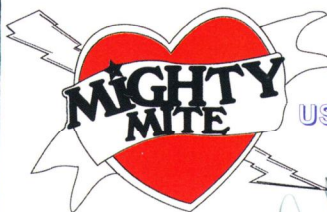

USA Retro-Fit

MMBM116C



MMBM116B



MMBM116G



MMBM025C

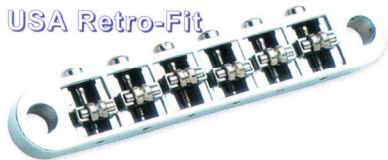

MMBM025G

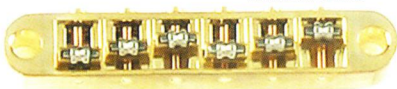

MMBM025B

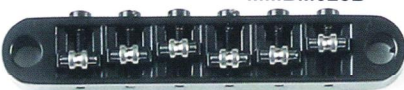

USA Retro-Fit

MMBM013G

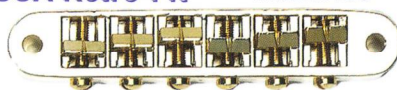

MMBM013C

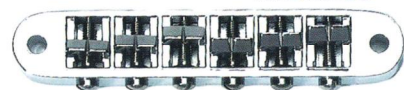

MMBM013B



MM2102

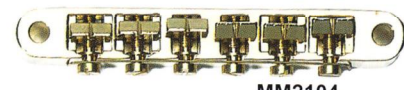

MM2104



USA Retro-Fit

MMLPT1G

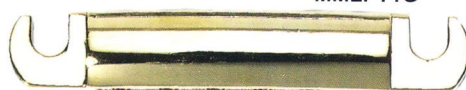

MMLPT1C



MMLPT1B



USA Retro-Fit

MMLPB1G

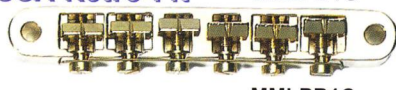

MMLPB1C



MMLPB1B



MM2105

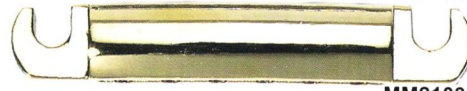

MM2103



USA Retro-Fit

MMBM004C

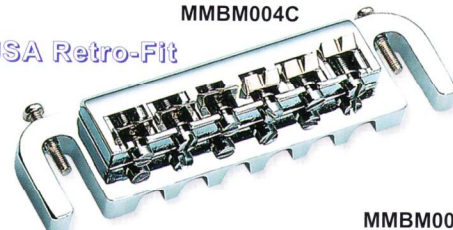

MMBM004B

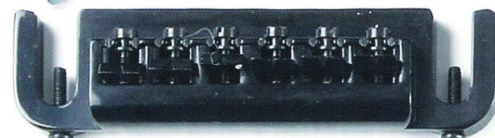

MMBM004G

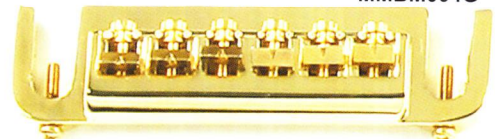

MM2106C/B/G

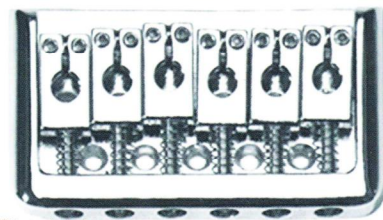

MMBL002C Floyd Rose® Style Bridge

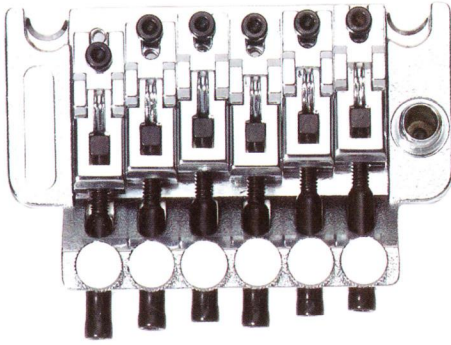

MMBL002B Floyd Rose® Style Bridge

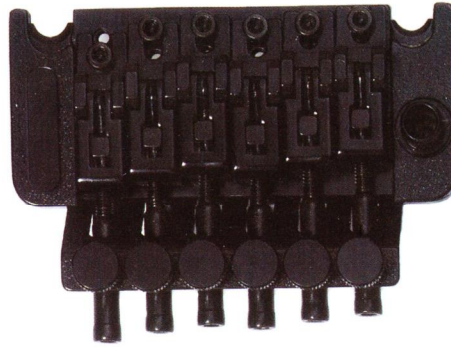

MMBL002G Floyd Rose® Style Bridge

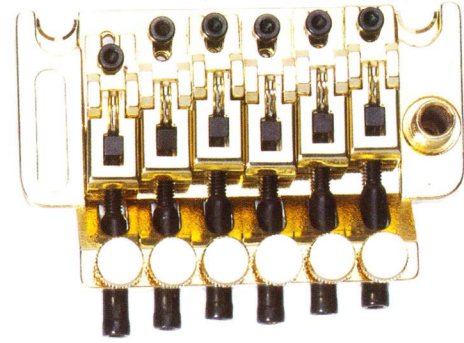

Mighty Mite® Floyd Rose® Replacement Parts

Part No.	Description	Ref No.
MM3000C	Base Plate (Chrome)	1
MM3000G	Base Plate (Gold)	1
MM3000B	Base Plate (Black)	1
MM3100	Fine Tuner Adjustment Spring	2
MM3200	Spring Holder Plate	3
MM3300	Tremolo Block / & Locking Screw	4/5
MM3500	Saddle Lock Down Screw (Pkg 6)	6
MM3600	String Holder Block (Pkg 6)	7
MM3700C	Bridge Saddle 1 & 6 (Chrome)	8
MM3700G	Bridge Saddle 1 & 6 (Gold)	8
MM3700B	Bridge Saddle 1 & 6 (Black)	8
MM3701C	Bridge Saddle 2 & 5 (Chrome)	8
MM3701G	Bridge Saddle 2 & 5 (Gold)	8
MM3701B	Bridge Saddle 2 & 5 (Black)	8
MM3702C	Bridge Saddle 3 & 4 (Chrome)	8
MM3702G	Bridge Saddle 3 & 4 (Gold)	8
MM3702B	Bridge Saddle 3 & 4 (Black)	8
MM3800	Fine Tuner Screw (Pkg 6)	9
MM3900	String Holder Locking Bolt (Pkg 2)	10
MM4000	Stud & Stud Insert G/B/C	11
MM4100	Tremolo Arm Bushing G/B/C	14
MM4100	Key Washer	15
MM4100	Bottom Washer	16
MM4103	Tremolo Arm Lock Nut G/B/C	17
MM4200	Spring Claw Hook	18
MM4300	Tremolo Springs (Pkg 6)	19
MM4400	Tremolo Claw Hook Screw (Pkg 10)	20

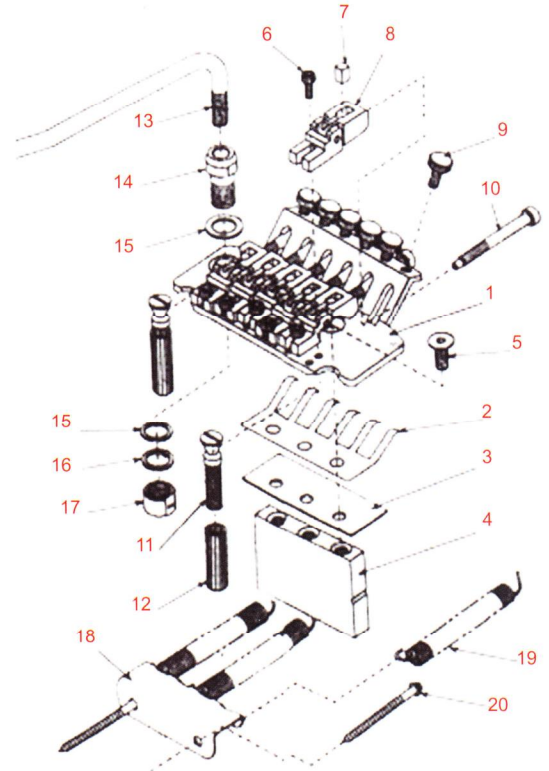

Original Floyd® Style Arms

MM1300G



MM1300C



MM1300B



Strat® Style Arms

MM1302



MM1304



Wilkinson® Style Arms

MM1308C

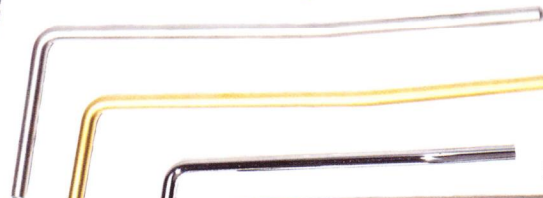

MM1308G

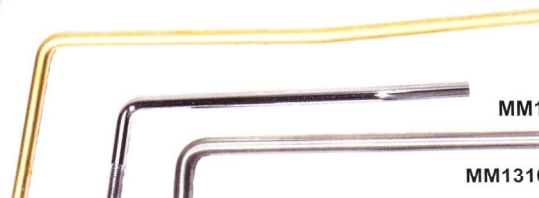

Floyd® III Style Arms

MM1306B



MM1306C



MM1306G



MM1301 - Vintage Strat



MM1310 - Long Floyd Arm

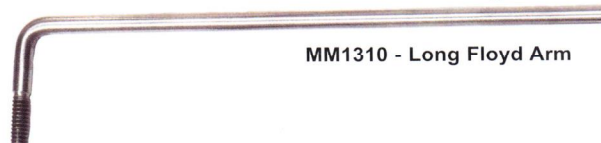

MMTA003G

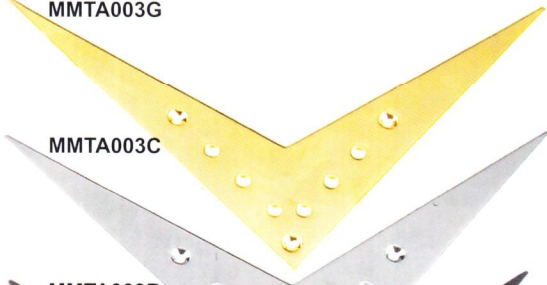

MMTA003C

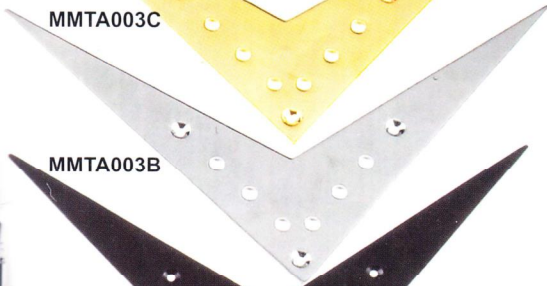

MMTA003B



MMTA001G



MMTA001C

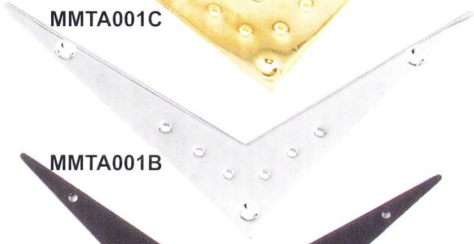

MMTA001B



MMTA002G

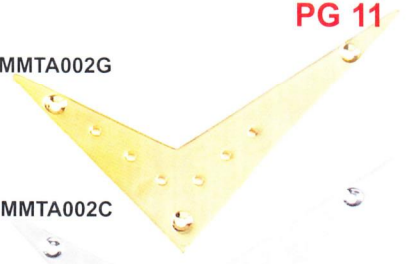

MMTA002C



MMTA002B



MMSM300G

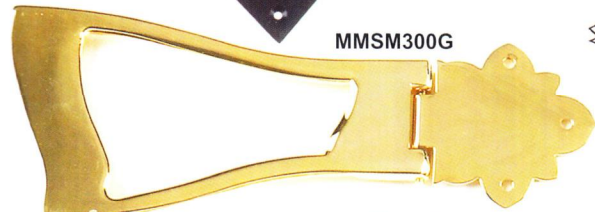

MMSM300C

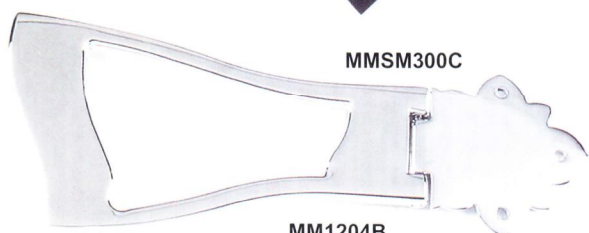

MM1204G

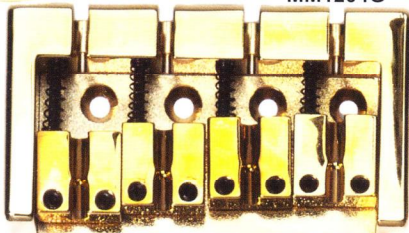

MM1204C

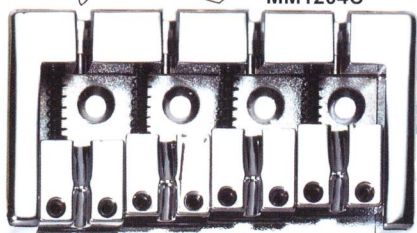

MM1204B

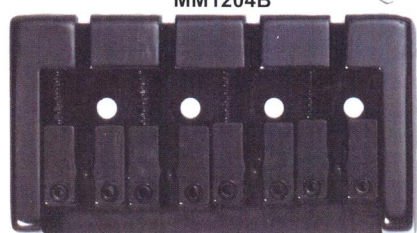

MM1205G

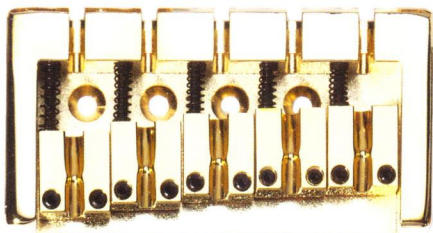

MM1205C

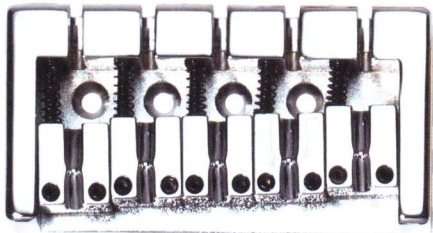

MM1205B

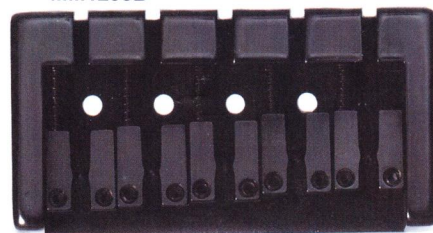

MM1206G

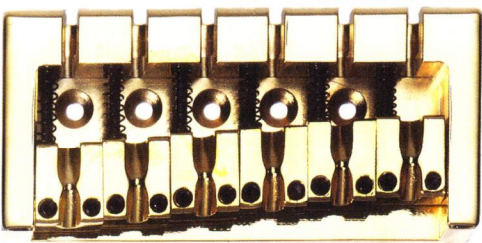

MM1206B

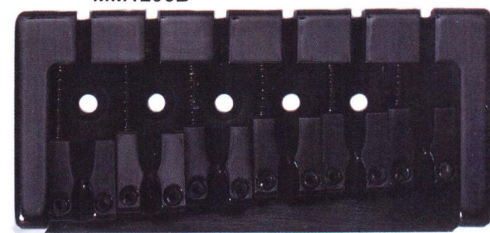

MM1110

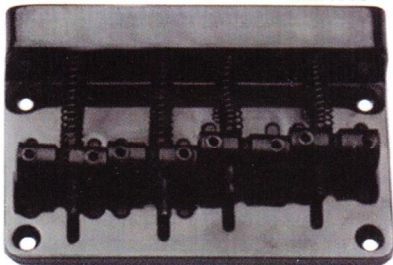

MM1115

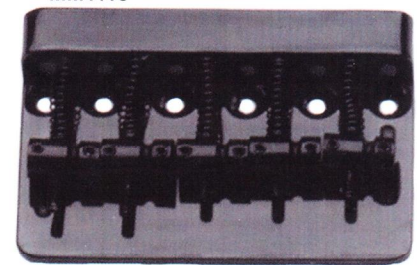

Available in Black or Chrome

Available in Black or Chrome



MMPL001C

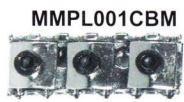

MMPL001CBM



MMPL001G



MMPL001GBM



MMPL001B



MMPL001BBM

Top Mount

Bottom Mount

MM1508C / G / B



MM1506C



MM1506G



MM1506B

MMHS001C



MMHS001G



MMHS001B

MM1600C



MM1600G



MM1600B



MM5612C/B/G



MM5610C/B/G

MM1100S



MMHS106G



MMHS106B



MMHS106C



MM1700

Set of 3
2.5MM / 3MM / 4MM



MM1701



Buttons Are Dunlop Compatible

MM508



MM534



MM504



MM514



MM535C



MM535G



MM535B



MM502C



USA Retro-Fit

MM502G



USA Retro-Fit

MM502B



USA Retro-Fit

MM507W



USA Retro-Fit

MM507CR



USA Retro-Fit

MM507B



USA Retro-Fit

43MM

MMPL002C



43MM

MMPL002CBM



MMPL002G

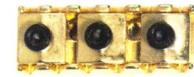

MMPL002GBM



MMPL002B



MMPL002BBM



Top Mount



Bottom Mount



MM2410



MM2400



MM2516



MM4300



MM2506



MM2300



MM2306



MM2302



MM2304



100 Pcs Of Pickguard Screws



MM2500



55 Pcs Of Assorted Nuts

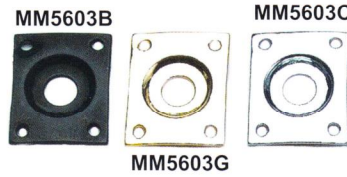
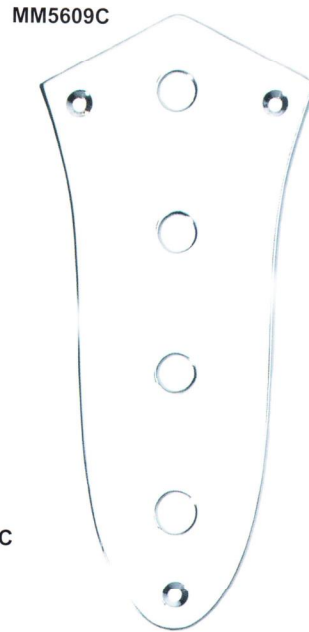
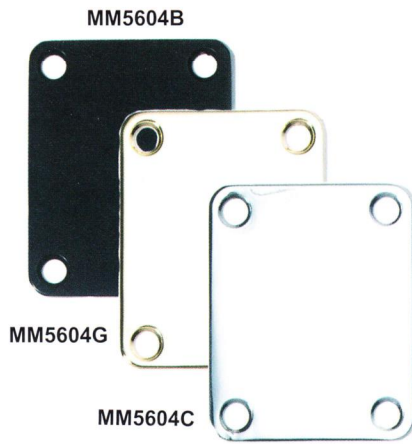
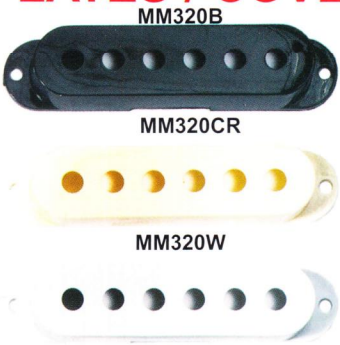

New USA Retro-Fit Gibson® Style Pickup Metal Rings, Fits All USA Les Pauls®. MM935G is Tall for the Bridge and MM933 is the Short for the Neck

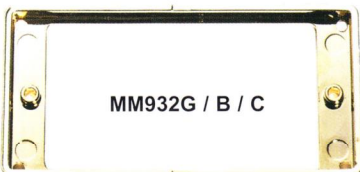
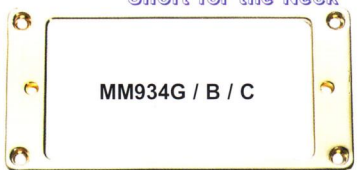
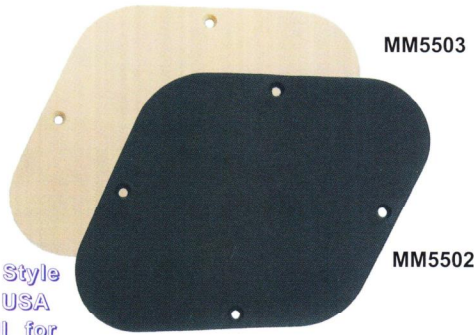

New Mighty Mite® Tall & Short Flat Metal Pickup Rings.

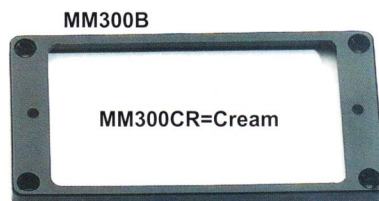
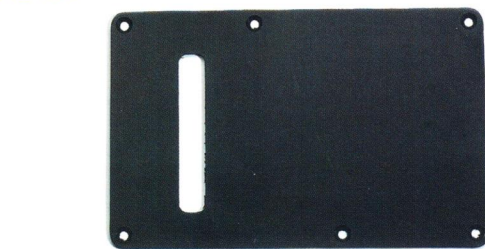

USA Retro-Fit

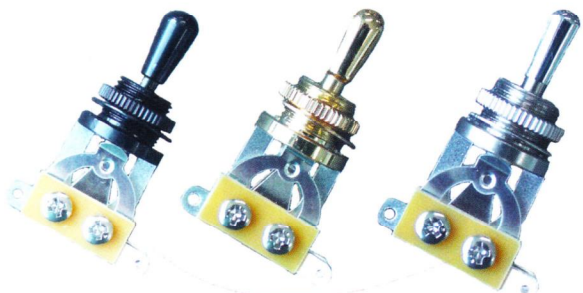

MM5020B

MM5020G

MM5020C



MM500
Mighty Mite® 3 Position
Toggle Switch (SPDT)
500 (Black) 501 (White)

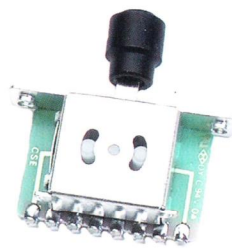

MM533
Mighty Mite® Tele®
Replacement
3 Way Switch With Black
Knob

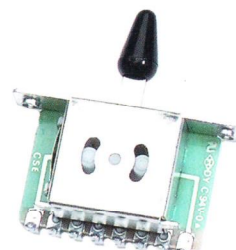

MM511
Mighty Mite® 3 Way
Switch
(Double Pole)
511 (Black) 512 (White)

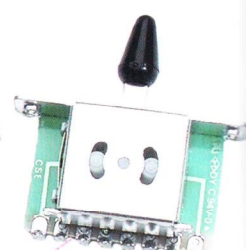

MM503
Mighty Mite® Strat®
Replacement
5 Way Switch With
Black Knob
(Double Pole)

New! Mighty Mite® Les Paul® Style Switch

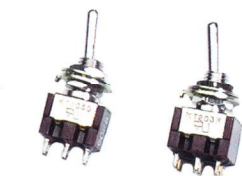

MM518 MM520
Mighty Mite® Mini
Toggles
518(SPDT) (520DPDT)



MM112
Mighty Mite® 1/4"
Barrel
End Pin Input Jack



MM111
Mighty Mite® 1/4"
Barrel
Input Jack
Sterio

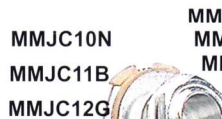

MMJC10N MMJC20N
MMJC11B MMJC21B
MMJC12G MMJC22G
Mighty Mite® 1/4" Mono &
Stereo Input Jacks
Available in Nickel / BIK / Gld

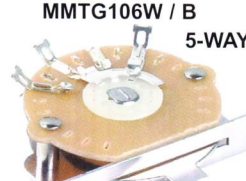

MMTG106W / B
5-WAY



MMTG107B / W
3-WAY

USA Retro-Fit

NEW!! Mighty Mite® Strat® & Tele® Style 5
way & 3 way Switches USA Retro Fit



MM700
Mighty Mite®
A250K Audio
Short Shaft
Dime Size



MM700L
Mighty Mite®
A250K Audio
Long Shaft
Dime Size



MM701
Mighty Mite®
B250K Linear
Short Shaft
Dime Size



MM701L
Mighty Mite®
B250K Linear
Long Shaft
Dime Size



MM702
Mighty Mite®
D500K Audio
Short Shaft
Dime Size



MM707
Mighty Mite®
A500K Audio
Short Shaft
Dime Size

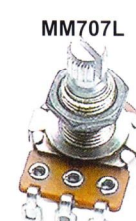

MM707L
Mighty Mite®
A500K Audio
Long Shaft
Dime Size



MM708
Mighty Mite®
B500K Linear
Short Shaft
Dime Size



MM708L
Mighty Mite®
B500K Linear
Long Shaft
Dime Size



MM709
Mighty Mite® A500K
Audio Control Pot
Quarter Size

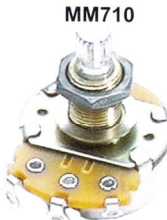

MM710
Mighty Mite® B500K
Linear Control Pot
Quarter Size

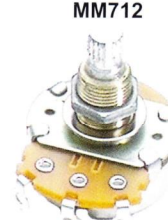

MM712
Mighty Mite® D500K
Audio Control Pot
Quarter Size

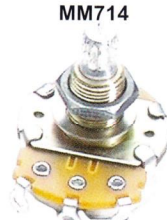

MM714
Mighty Mite® A250K
Audio Control Pot
Quarter Size



MM716
Mighty Mite® B250K
Linear Control Pot
Quarter Size
Short Shaft

New!! Mighty Mite® Sealed Control Pots



MM703
Mighty Mite®
Push-Pull
A250K Audio



MM704
Mighty Mite®
Push-Pull
A500K Audio

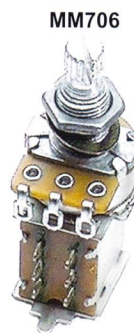

MM706
Mighty Mite®
Push-Pull
B500K Audio



MM717
Mighty Mite®
A250K Audio
Long Shaft
Quarter Size



MM717L
Mighty Mite®
B250K Linear
Long Shaft
Quarter Size



MM718
Mighty Mite®
A500K Audio
Long Shaft
Quarter Size



MM718L
Mighty Mite®
B500K Linear
Long Shaft
Quarter Size



MM916/920



MM914/918



MM917/919



MM910/912



MM922



MM908



MMKN007GC



MMKN007BG



MMKN007CC



MMKN007CG



MMNP002GAT



MMNP002CAT



MMNP002BAT



MMNS006G



MMNP002GWP



MMNP002CWP



MMNP002BWP



MMNS006C



MMNS001CAT



MMNS001GAT



MMNS001BAT



MM909G

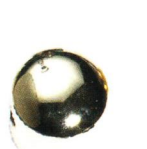

MMNS006B



MMNS001CWP



MMNS001GWP



MMNS001BWP



MM909C



MMNS003G/C/B



MMNS001CBP



MMNS001GBP



MMNS001BBP



MM909B



MM913CR



MM902



MM904



MM900



MM913BK



MM913AM

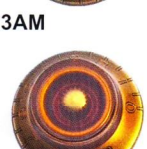
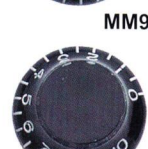



MMJ01

3X3 Tuners,
Available In,
Chrome-Black
& Gold
Set Of 6



MMJ101

3X3 Tuners,
Available In,
Chrome-Black
& Gold
Set Of 6



MMJ026

6 In-line Tuners,
Available In,
Chrome-Black
& Gold
Set Of 6



MMJ04

3X3 Tuners,
Available In,
Chrome-Black
& Gold
Set Of 6



MMJ44

3X3 Tuners,
Available In,
Nickel & Gold
Set Of 6



MMJ807

3X3 Tuners,
Available In,
Chrome-Black
& Gold
Set Of 6



MMJ056

6 In-Line Tuners,
Available In,
Chrome-Black
& Gold
Set Of 6



MMJ805

6 In-Line Tuners,
Available In,
Chrome-Black
& Gold
Set Of 6

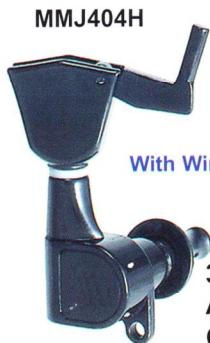

MMJ404H

With Winder

3X3 Tuners,
Available In,
Chrome-Black
& Gold
Set Of 6

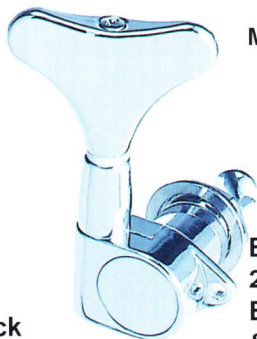

MMJB150

Bass Tuners,
2x2 / 3x2
Black-Chrome
& Gold

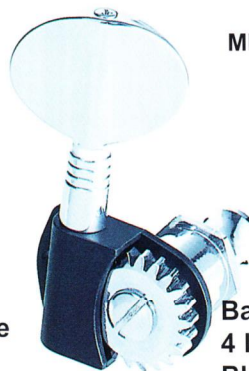

MMJB300

Bass Tuners,
4 In-Line
Black-Chrome
& Gold

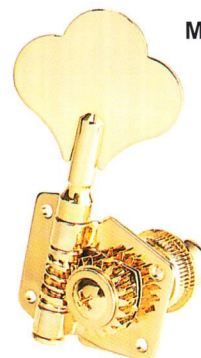

MMJB200

Bass Tuners,
4 In-Line
Black-Chrome
& Gold

New!! Mighty Mite® Machine Head Buttons, Each is available packaged in sets of 6 and in chrome black or gold. Just add C-B-G at the end of the item number for the color.



MMK01



MMK03



MMK03M



MMK04



MMK04H



MMK09



MMKB1



MMKB4



MMKB5



Switch Knobs 10-BK504 10-BK514 10-BK506 10-BK515 10-BK508 10-BK516 10-BK510 10-BK534	Input Jacks 3-BK111 3-BK112	Bridge Pins & End Pins 10-BK2300B / 3-BK2300E 10-BK2302B / 3-BK2302E 10-BK2304B / 3-BK2304E	Strat® Knobs 2-BK914 2-BK916 2-BK917 2-BK918 2-BK919 2-BK920	Strap Button 4-BK5610B 4-BK5610C 4-BK5610G 4-BK5612B 4-BK5612C 4-BK5612G	
Tremolo Arms 2-BK1302 / 4-BK1300 / 2-BK1304	Retainer Bar / Tree's 2-BK1506B 5-BK1508B 2-BK1506C 5-BK1508C 1-BK1506G 3-BK1508G		Locking Nuts 2-BKPL001C 2-BKPL002B 2-BKPL002C 2-BKPL001G 2-BKPL001B 2-BKPL002G		
Strat Recessed Jack Plates 2-BK5600-BLK 2-BK5601-CHRM 2-BK5602-GLD 2-BK5603C 2-BK5603G 2-BK5603B	Assorted Nuts BK2500 / 55 Pkg Acoustic Saddles 15 (Pkg)	Hooks Springs Screws 3-BK4200 15-BK4300 10-BK4400	Switches 2-BK500 2-BK503 2-BK511 2-BK518 2-BK520	Humbucker Mounting Rings 2-BK300B-S 2-BK300B-T 2-BK300CR-S 2-BK300CR-T	Pots 2-BK700 2-BK702 2-BK703 2-BK704 2-BK706 2-BK710 2-BK712 2-BK714 30-Wash/Nut

Item	Description	Qty/RK1	Qty/RK2	Item	Description	Qty/RK1	Qty/RK2
BK111	1/4" Barrel Style Input Jack	7	3	BKPL001C	Locking Nut / Complete Set w/ Wrench 1-5/8" (Chrome)	5	2
BK112	1/4" Barrel Style End Pin Input Jack	7	3	BKPL002C	Locking Nut / Complete Set w/ Wrench 1-11/16" (Chrome)	5	2
BK300B-S	Short Plastic Humbucker Pickup Ring (Black)	5	2	BKPL001B	Locking Nut / Complete Set w/ Wrench 1-5/8" (Black)	5	2
BK300B-T	Tall Plastic Humbucker Pickup Ring (Black)	5	2	BKPL002B	Locking Nut / Complete Set w/ Wrench 1-11/16" (Black)	5	2
BK300CR-S	Short Plastic Humbucker Pickup Ring (Cream)	5	2	BKPL001G	Locking Nut / Complete Set w/ Wrench 1-5/8" (Gold)	5	2
BK300CR-T	Tall Plastic Humbucker Pickup Ring (Cream)	5	2	BKPL002G	Locking Nut / Complete Set w/ Wrench 1-11/16" (Gold)	5	2
BK500	3 Position Toggle Switch (Black Knob)	5	2	BK1506C	String Retainer Bar (Chrome)	5	2
BK503	5 Way Switch (Black Knob)	5	2	BK1506B	String Retainer Bar (Black)	5	2
BK504	Knobs For 3 & 5 Way Switch (Black)	22	10	BK1506G	String Retainer Bar (Gold)	3	1
BK506	Knobs For 3 & 5 Way Switch (Cream)	22	10	BK1508C	Roller String Tree (Chrome)	11	5
BK508	Knobs For 3 Position Toggle Switch (Black)	22	10	BK1508B	Roller String Tree (Black)	11	5
BK510	Knobs For 3 Position Toggle Switch (Cream)	22	10	BK1508G	Roller String Tree (Gold)	5	3
BK511	3 Way Switch (Black Knob)	5	2	BK2300B	Bridge Pin / White w/ Black Dot	22	10
BK514	Knobs For 5 Way Switch (Black)	22	10	BK2300E	End Pin / White w/ Black Dot	7	3
BK515	Knobs For 5 Way Switch (Cream)	22	10	BK2302B	Bridge Pin / Black w/ White Dot	22	10
BK516	Knobs For 5 Way Switch (White)	22	10	BK2302E	End Pin / Black w/ White Dot	7	3
BK518	Mini Toggle Switch / 3 Single Terminal System	5	2	BK2304B	Bridge Pin / Cream w/ Black Dot	22	10
BK520	Mini Toggle Switch / 3 Dual Terminal System	5	2	BK2304E	End Pin / Cream w/ Black Dot	7	3
BK534	Knobs For 3 Way Switch (Black)	22	10	BK2400	Acoustic Guitar Saddle (Cream)	33	15
BK700	Control Pot / A250K Audio Short Shaft Dime Size	5	2	BK2500	Assorted String Nut Package / 55 Pcs	110 / PCS	55 / PCS
BK702	Control Pot / D500K Audio Short Shaft Dime Size	5	2	BK4200	Tremolo Spring Claw Hook	7	3
BK703	Control Pot / A250K Audio Push Pull	5	2	BK4300	Tremolo Springs	33	15
BK704	Control Pot / A500K Audio Push Pull	5	2	BK4400	Tremolo Spring Claw Hook Screw	22	10
BK706	Control Pot / B500K Linear Push Pull	5	2	BK5600	Strat® Replacement Recessed Jack Plate (Black)	5	2
BK710	Control Pot / B500K Linear Quarter Size	5	2	BK5601	Strat® Replacement Recessed Jack Plate (Chrome)	5	2
BK712	Control Pot / D500K Audio Quarter Size	5	2	BK5602	Strat® Replacement Recessed Jack Plate (Gold)	5	2
BK714	Control Pot / A250K Audio Quarter Size	5	2	BK5603B	Les Paul® Replacement Jack Plate (Black)	5	2
BK914	Control Knob / Strat® Replacement / Volume (Black)	5	2	BK5603C	Les Paul® Replacement Jack Plate (Chrome)	5	2
BK916	Control Knob / Strat® Replacement / Volume (White)	5	2	BK5603G	Les Paul® Replacement Jack Plate (Gold)	5	2
BK917	Control Knob / Strat® Replacement / Volume (Cream)	5	2	BK5610B	Strap Button / Traditional Style (Black)	9	4
BK918	Control Knob / Strat® Replacement / Tone (Black)	9	4	BK5610C	Strap Button / Traditional Style (Chrome)	9	4
BK919	Control Knob / Strat® Replacement / Tone (Cream)	9	4	BK5610G	Strap Button / Traditional Style (Gold)	9	4
BK920	Control Knob / Strat® Replacement / Tone (White)	9	4	BK5612B	Strap Button / Contemporary Style (Black)	9	4
BK1300C	Tremolo Arm / Floyd Rose® Replacement (Chrome)	9	4	BK5612C	Strap Button / Contemporary Style (Chrome)	9	4
BK1302	Tremolo Arm / Strat® Replacement / (White Knob)	5	2	BK5612G	Strap Button / Contemporary Style (Gold)	9	4
BK1304	Tremolo Arm / Strat® Replacement / (Black Knob)	5	2				

NOTE: RK1, Control Pots Come With 60 pcs Of Extra Washers & Nuts
 RK2, Control Pots Come With 30 pcs Of Extra Washers & Nuts

MM2500 String Nut Package
 5- Acoustic Style 1-11/16" (White)
 5- Les Paul® Style 1-11/16" (Cream)
 6- Acoustic Style 1-11/16" (Cream)
 5- Les Paul® Style 1-11/16" (White)
 4- Classical Style 2" (White)
 5- Acoustic Style 1-11/16" (Black)
 6- Les Paul® Style 1-11/16" (Black)

4- 5 String Bass Style 1-3/4" (Black)
 5- 4 String Bass Style 1-11/16" (Black)
 5- 4 String Bass Thin Style 43X3T (Black)
 5- Electric Guitar Style 43X3T (Cream)

NOTE: RK1 comes with 2 MM2500 Packages

MMSK1



Neck Plate Screws 50-BK7100C 50-BK7100B 25-BK7100G	Humbucker Pickup Screws 100-BK7700B 100-BK7700C 25-BK7700G	Strap Button Screws 50-BK7400B	Strap Button Screws 50-BK7400C
Pickguard Screws 100-BK7000B 100-BK7000C 100-BK7000G	Machine Head Screws 100-BK730B 100-BK730C	Guitar Pickup Screws 100-BK7500B	Strap Button Screws 25-BK7400G
	Humbucker Ring Screws 100-BK7200B-SHRT 100-BK7200B-TALL 100-BK7200C-SHRT 100-BK7200C-TALL	Humbucker Ring Springs 50-BK7800	Bass Guitar Pickup Screws 100-BK7600C 100-BK7600B

7200G-S
 7200G-T

MMBGPRENER

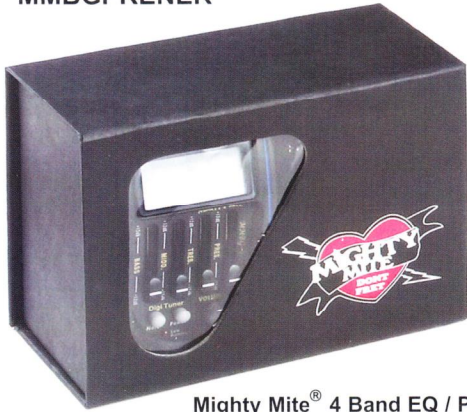

Mighty Mite® 4 Band EQ / Pre-Amp
w/ Piezo® Under Bridge Mount Pickup



MMBG3TN



Mighty Mite® 3 Band EQ / Pre-Amp
w/ Piezo® Under Bridge Mount Pickup



MMATN-300



Mighty Mite® Mini EQ / Pre-Amp
w/ Piezo® Under Bridge Mount Pickup



MMA106



Mighty Mite® Folk Piezo® Cable Pickup

MMA108



Mighty Mite® Bass Piezo® Cable Pickup





NEW!! US Retro Strat® Style Accessory Kits

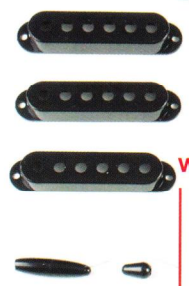
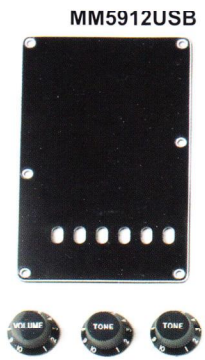

Pickup Spacing is USA Retro Fit and will fit most USA Made Pickups

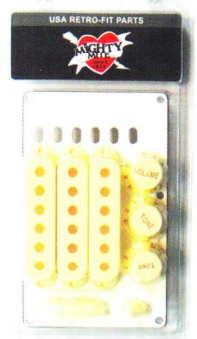

With Matching Pickguards

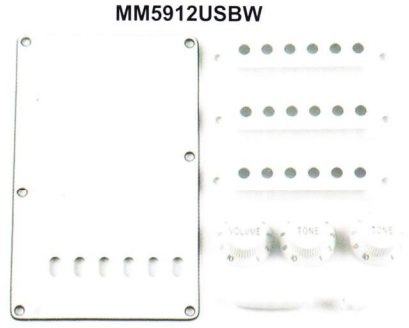
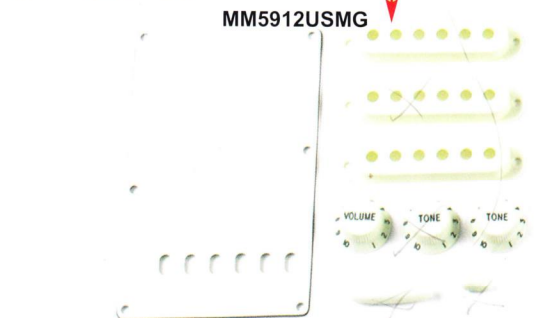
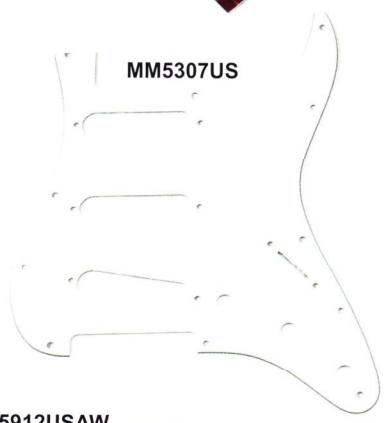

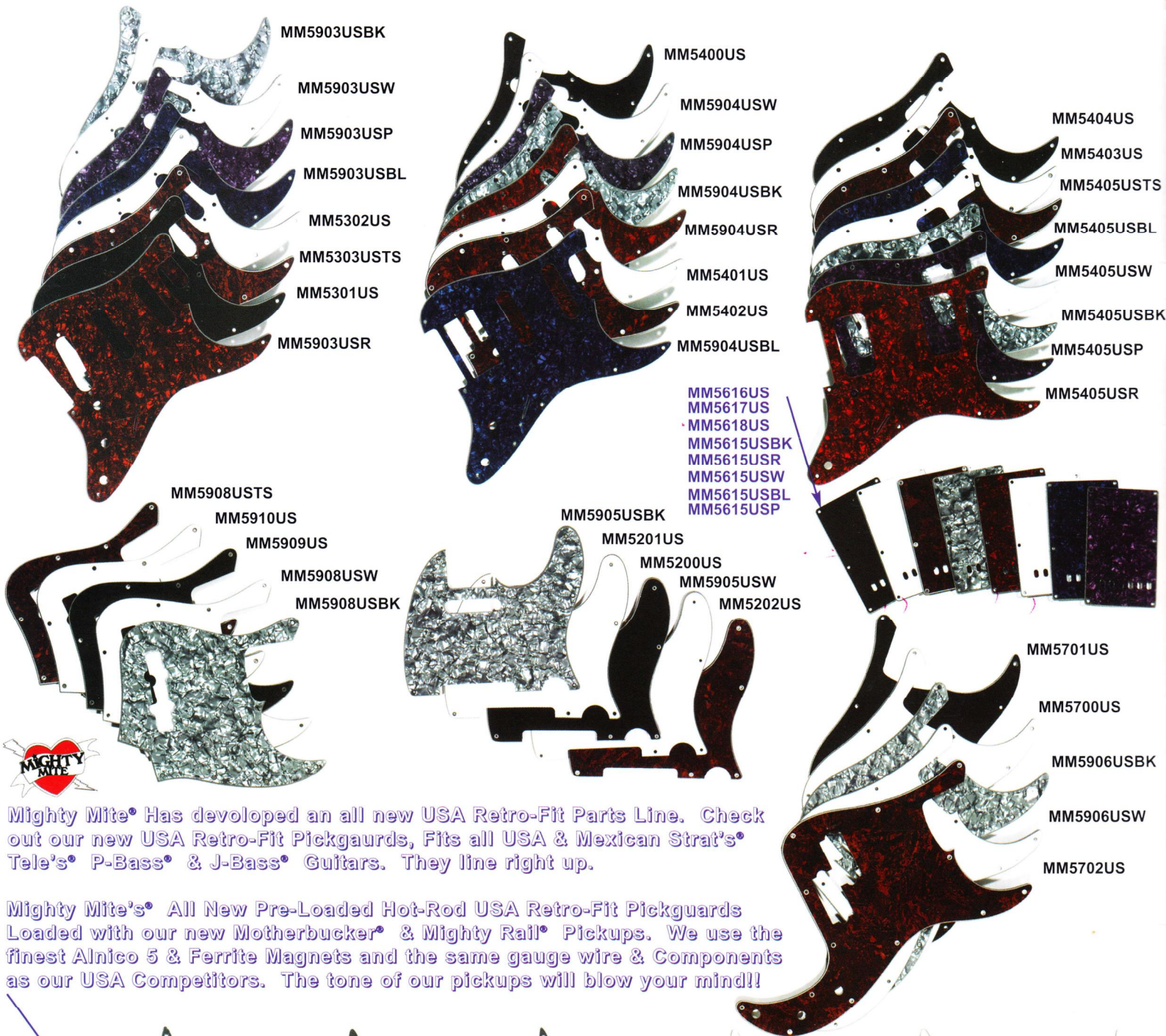

Mighty Mite® Has developed an all new USA Retro-Fit Parts Line. Check out our new USA Retro-Fit Pickguards, Fits all USA & Mexican Strat's® Tele's® P-Bass® & J-Bass® Guitars. They line right up.

Mighty Mite's® All New Pre-Loaded Hot-Rod USA Retro-Fit Pickguards Loaded with our new Motherbucker® & Mighty Rail® Pickups. We use the finest Alnico 5 & Ferrite Magnets and the same gauge wire & Components as our USA Competitors. The tone of our pickups will blow your mind!!

